

PASSERINCA

USER MANUAL OF GP_15

1/18 RC MOTORCYCLE ATR KIT

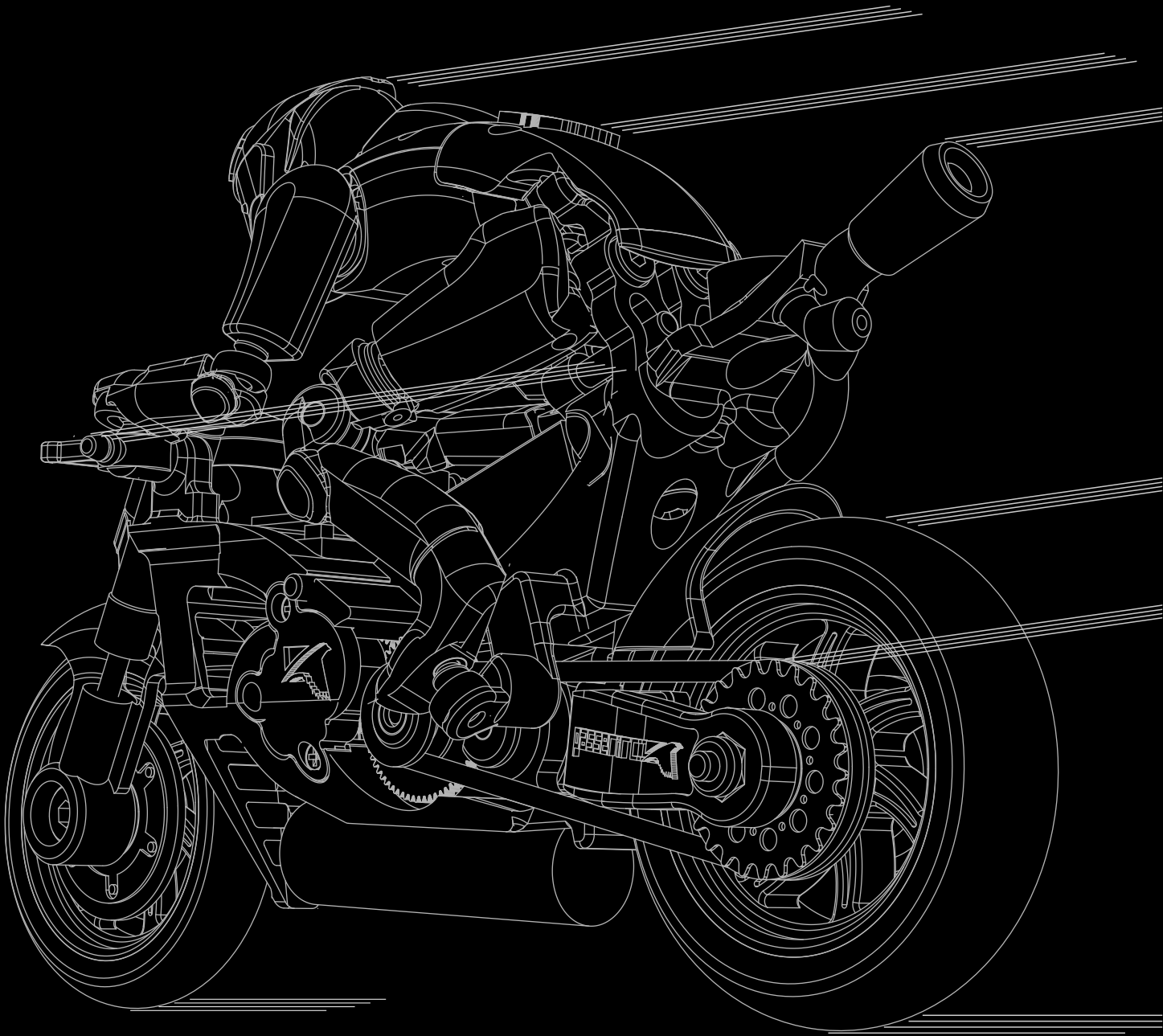

A - KEVIN ASSEMBLE

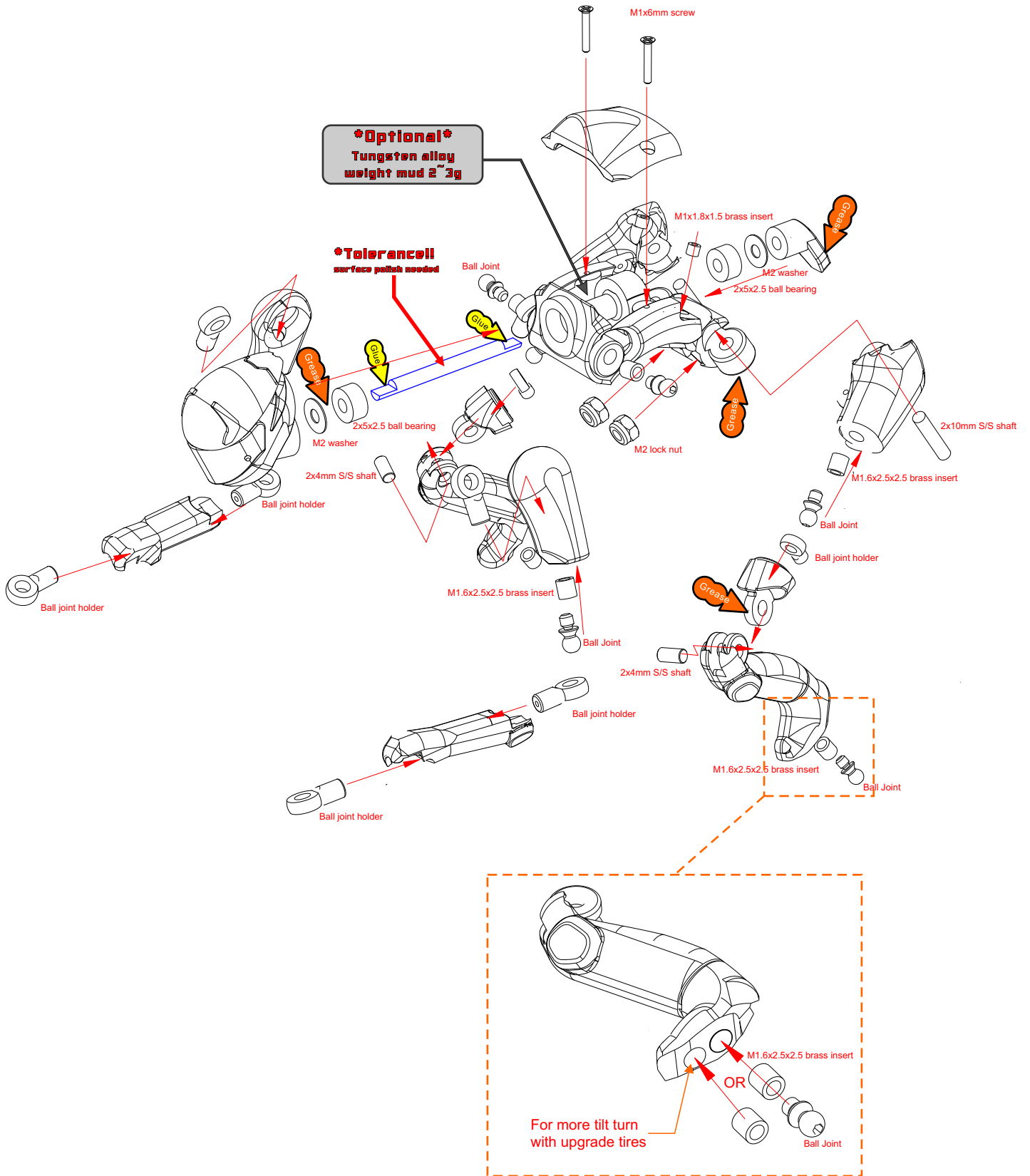

A - KEVIN ASSEMBLE

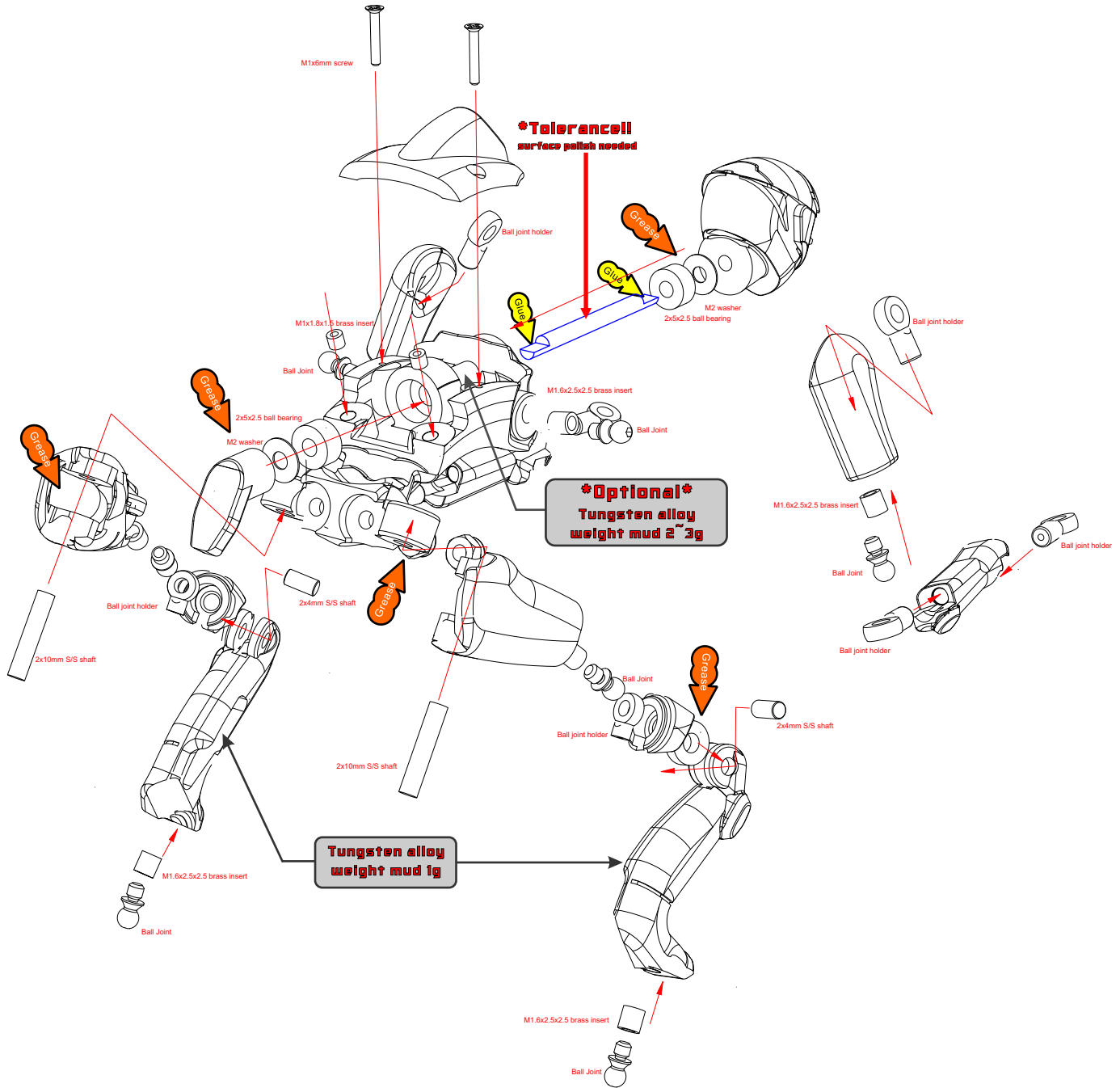

A - KEVIN ASSEMBLE

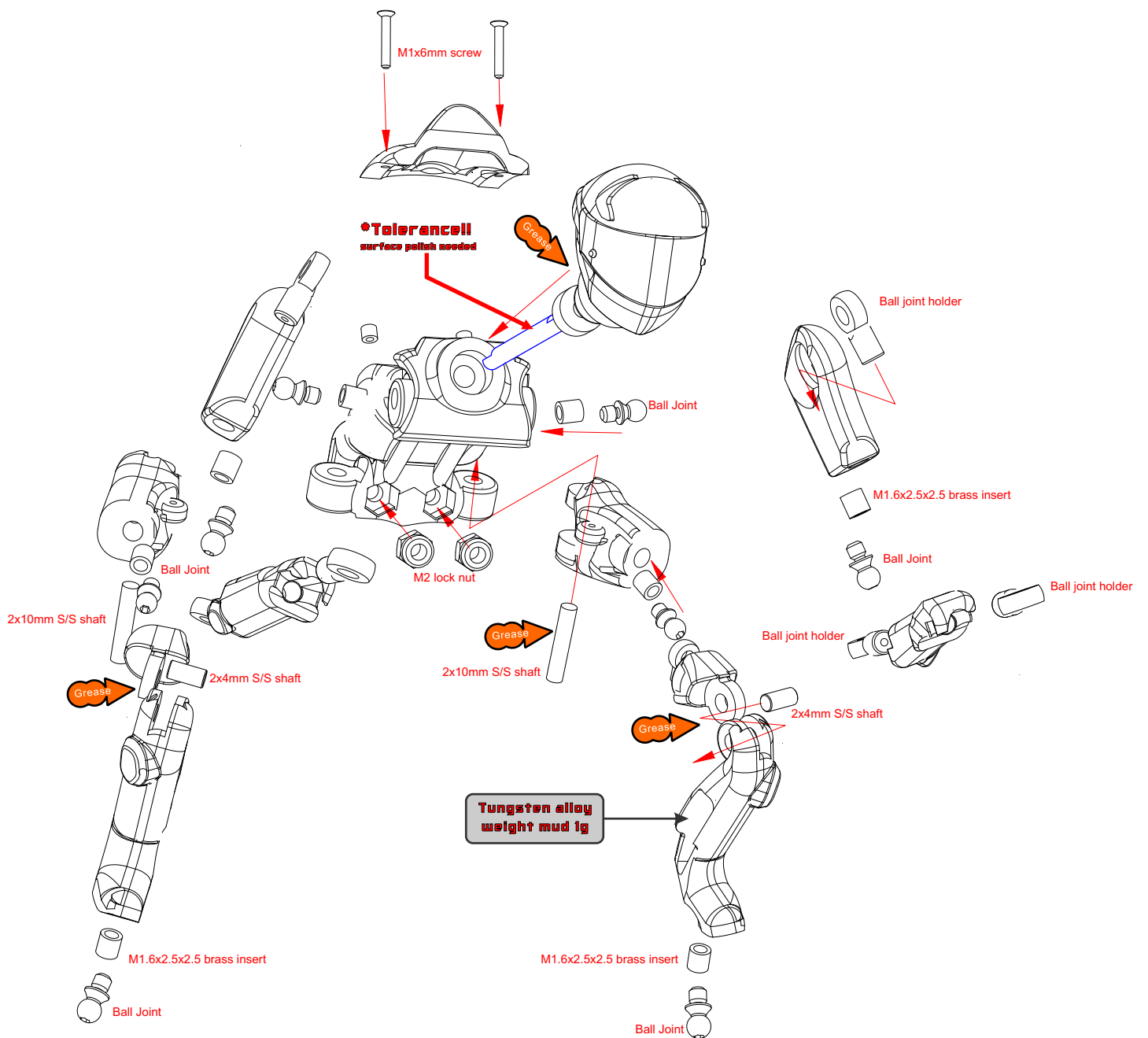

B - CHASSIS ASSEMBLE

FRONT WHEEL, FORK TUBE AND FENDER

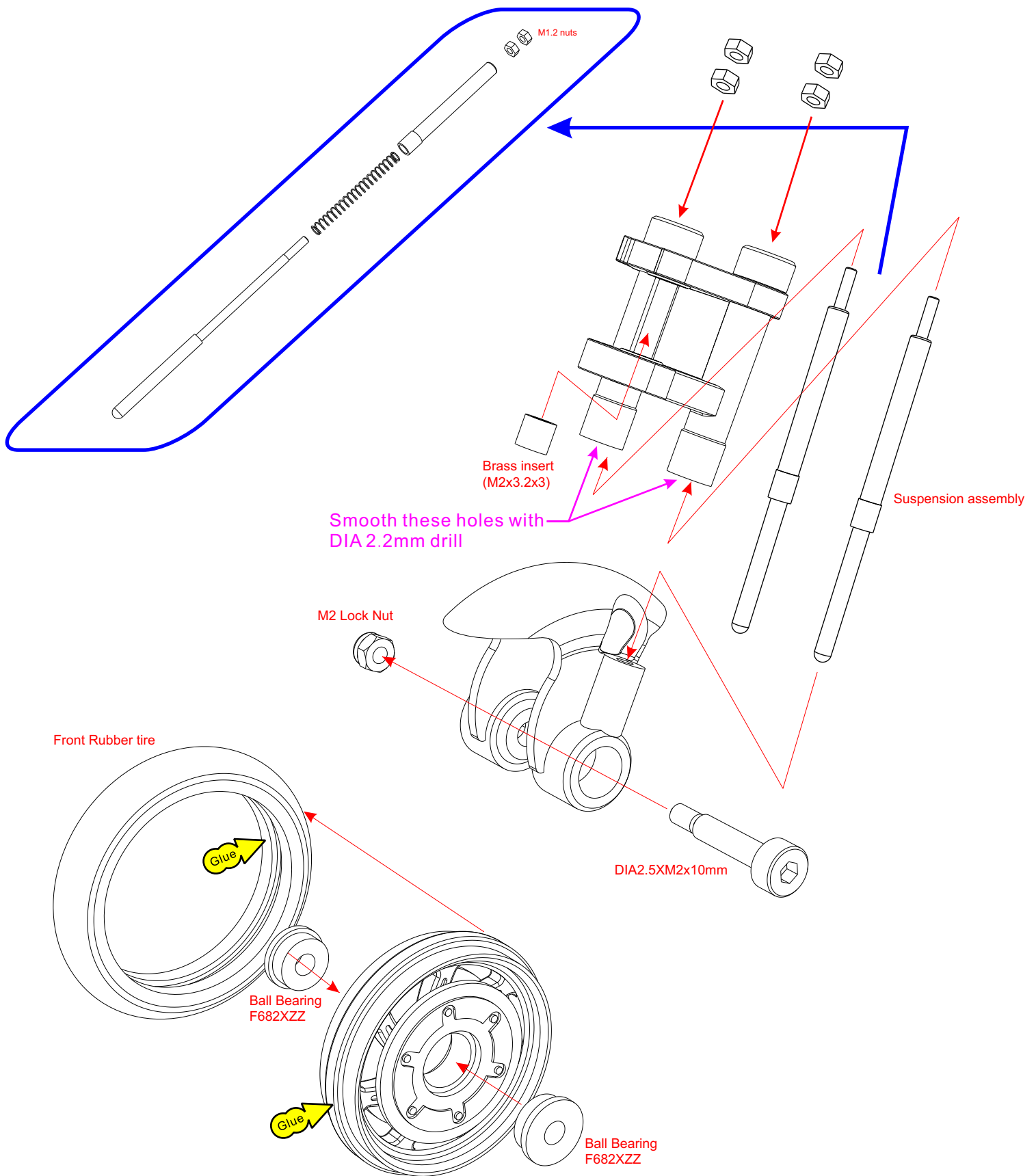

B - CHASSIS ASSEMBLE

REAR WHEEL AND SWING ARM

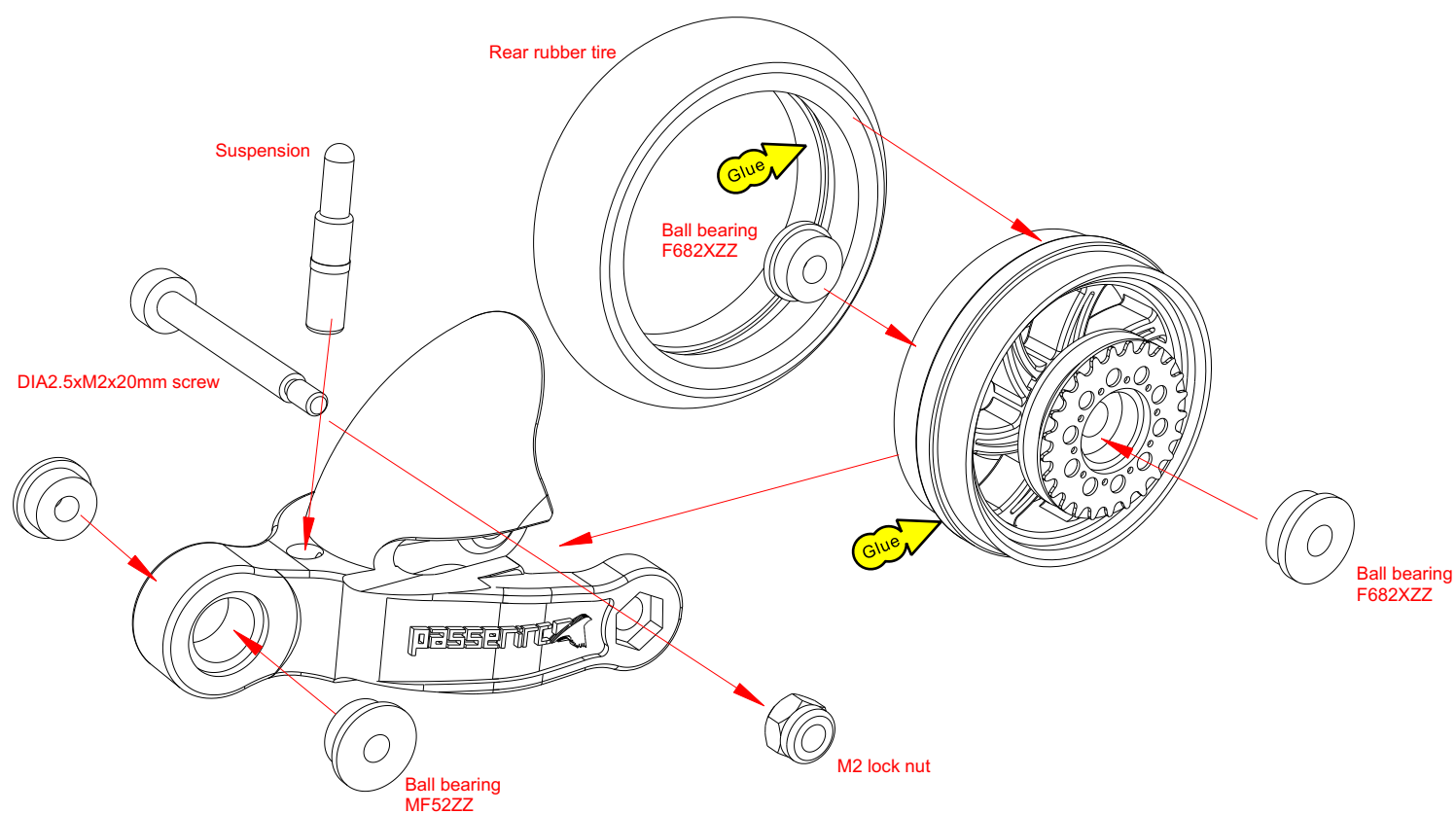

B - CHASSIS ASSEMBLE

SERVO AND LEVERS

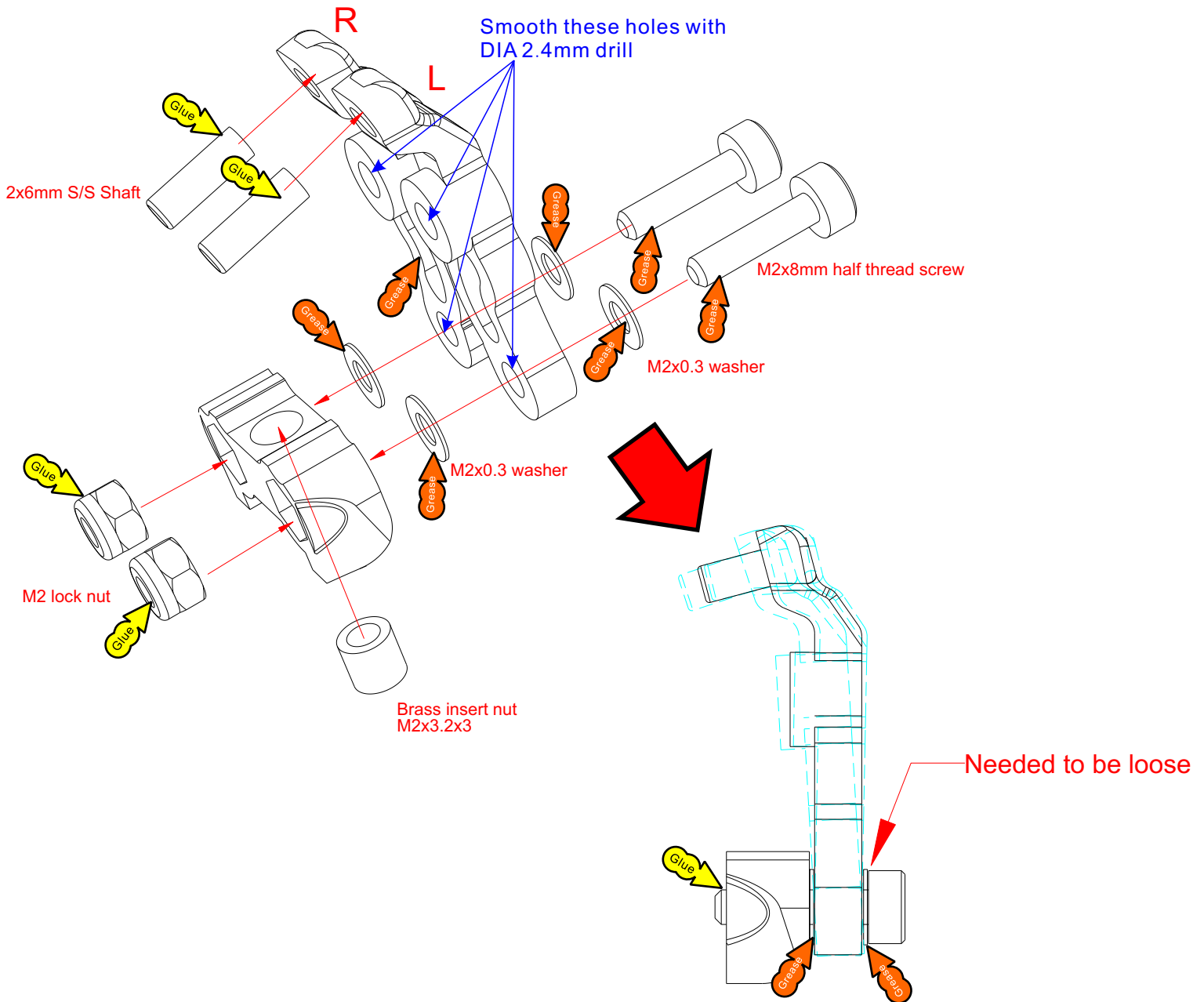
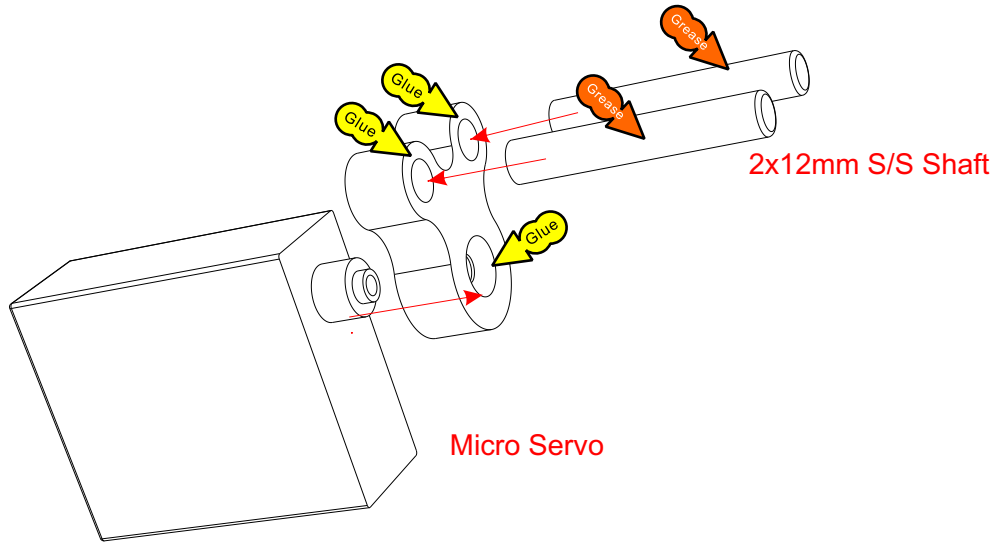

B - CHASSIS ASSEMBLE

CHASSIS

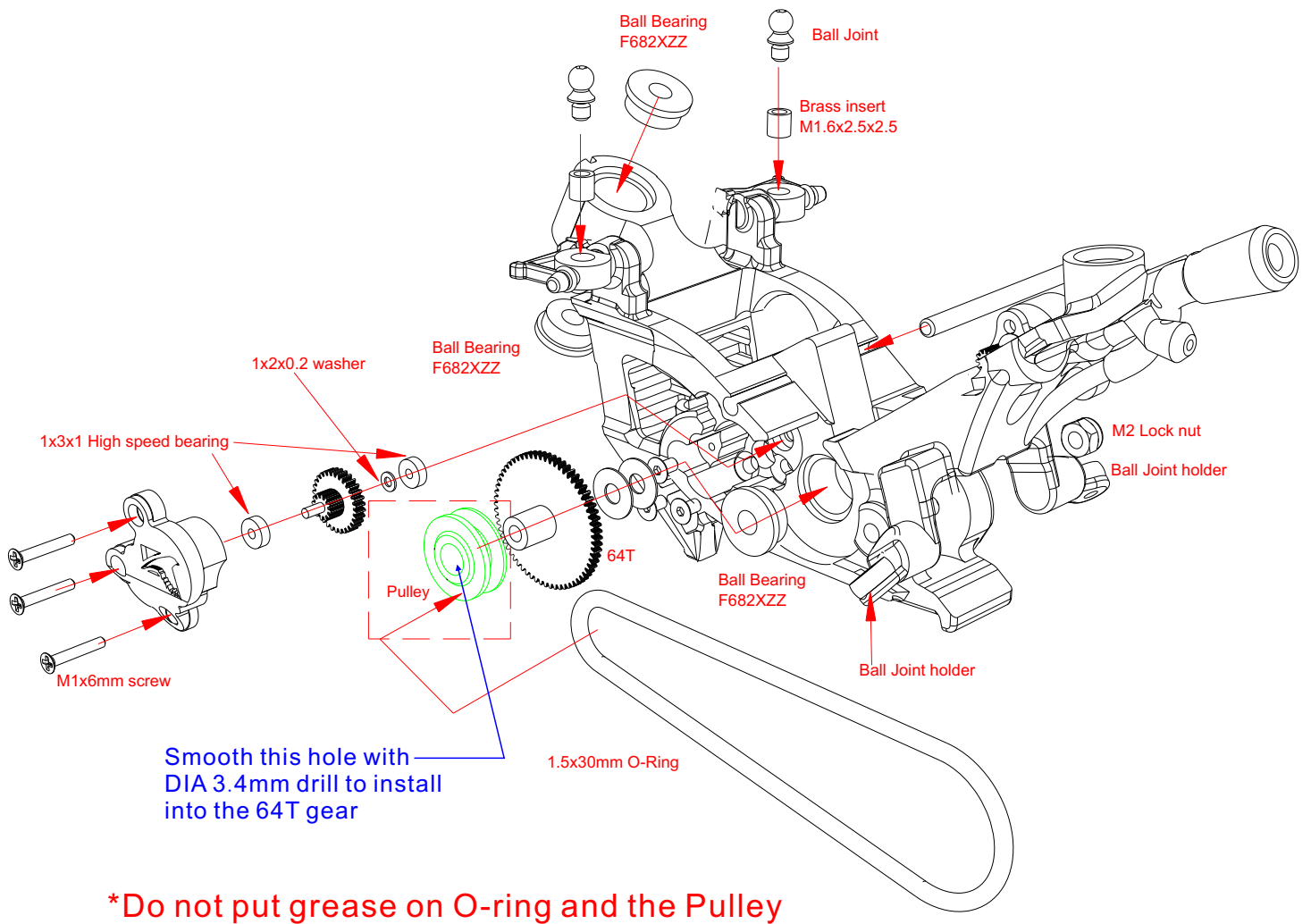

B - CHASSIS ASSEMBLE

CHASSIS

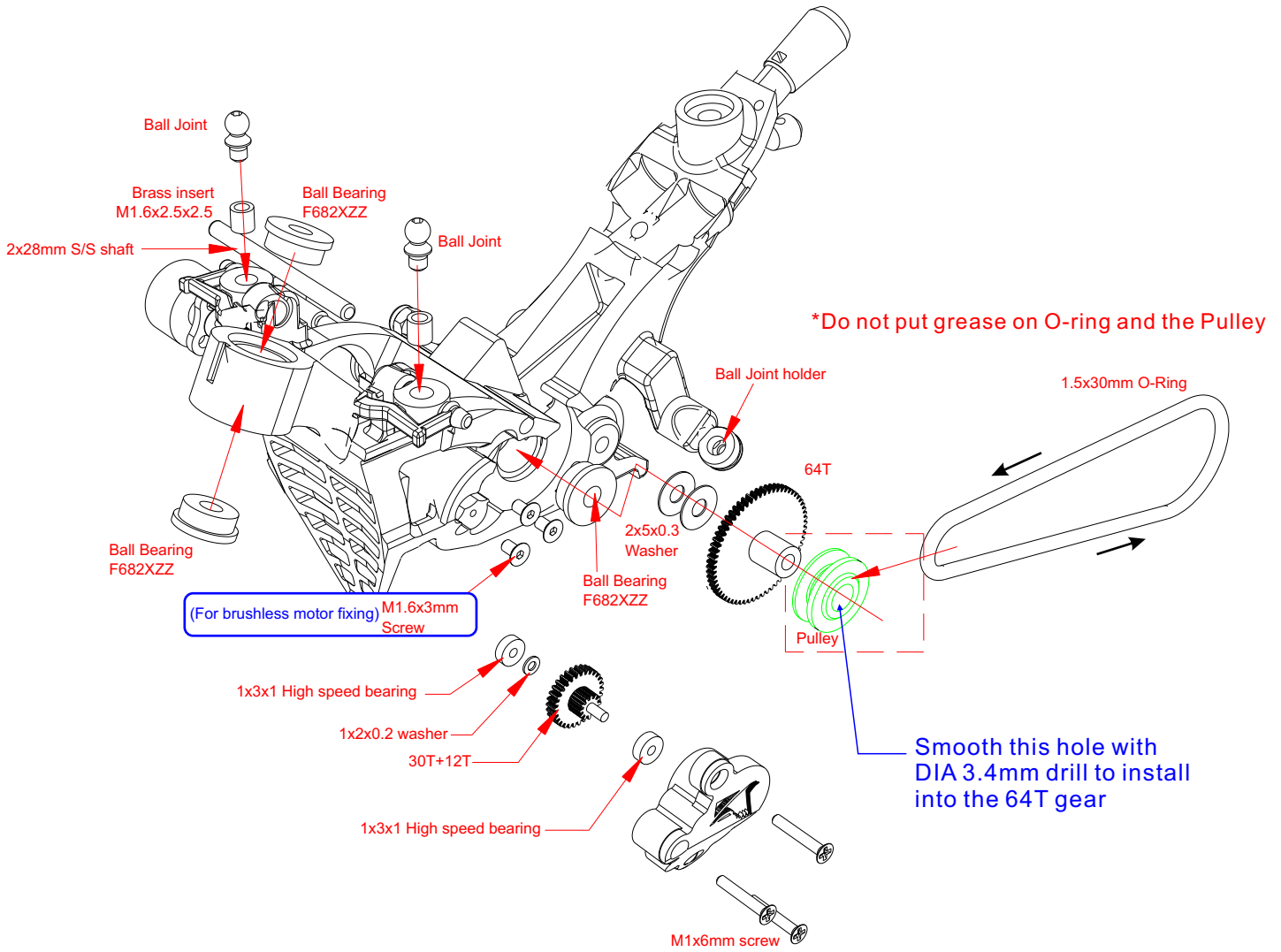

B - CHASSIS ASSEMBLE

CHASSIS

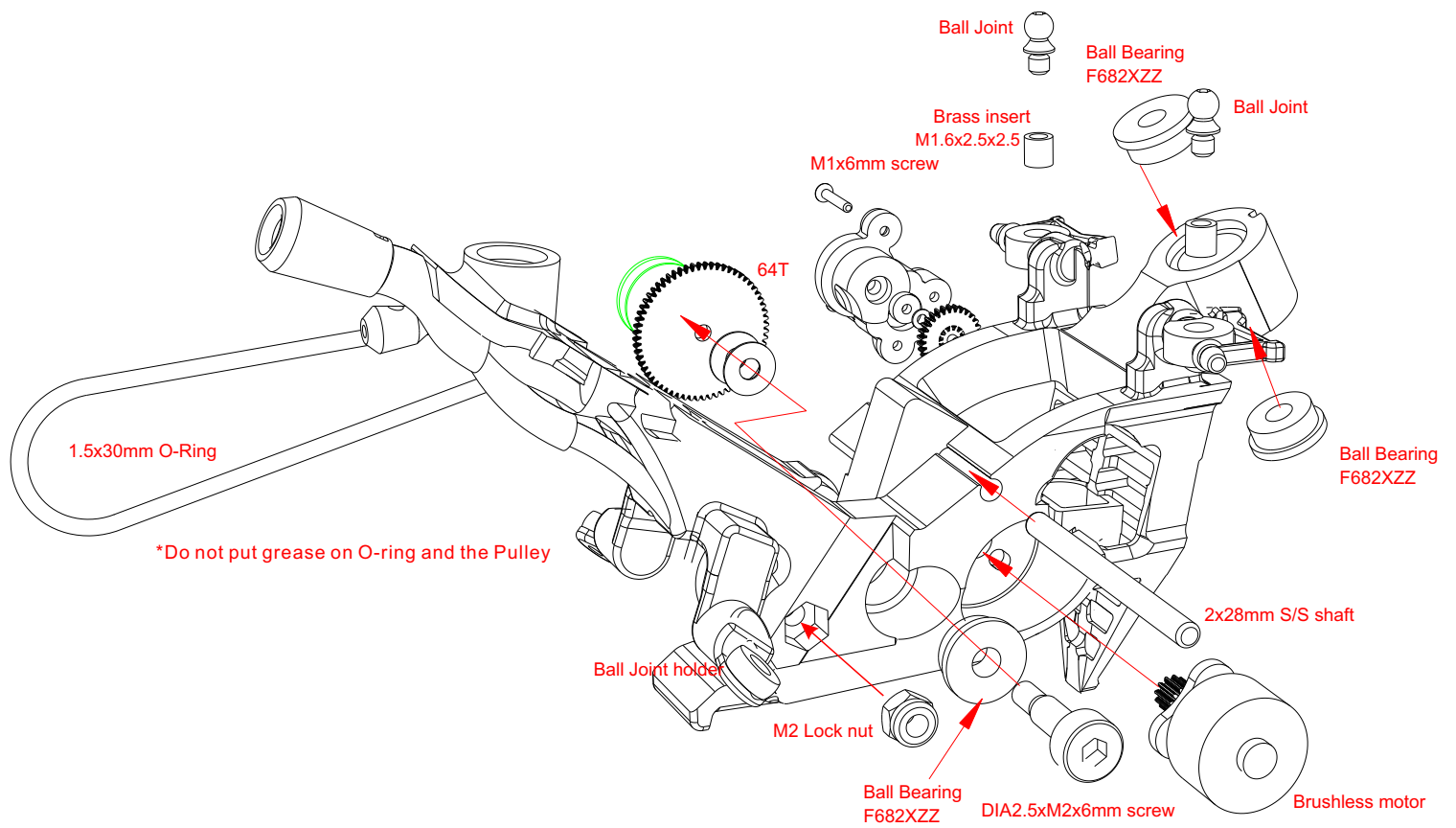

B - CHASSIS ASSEMBLE

CHASSIS

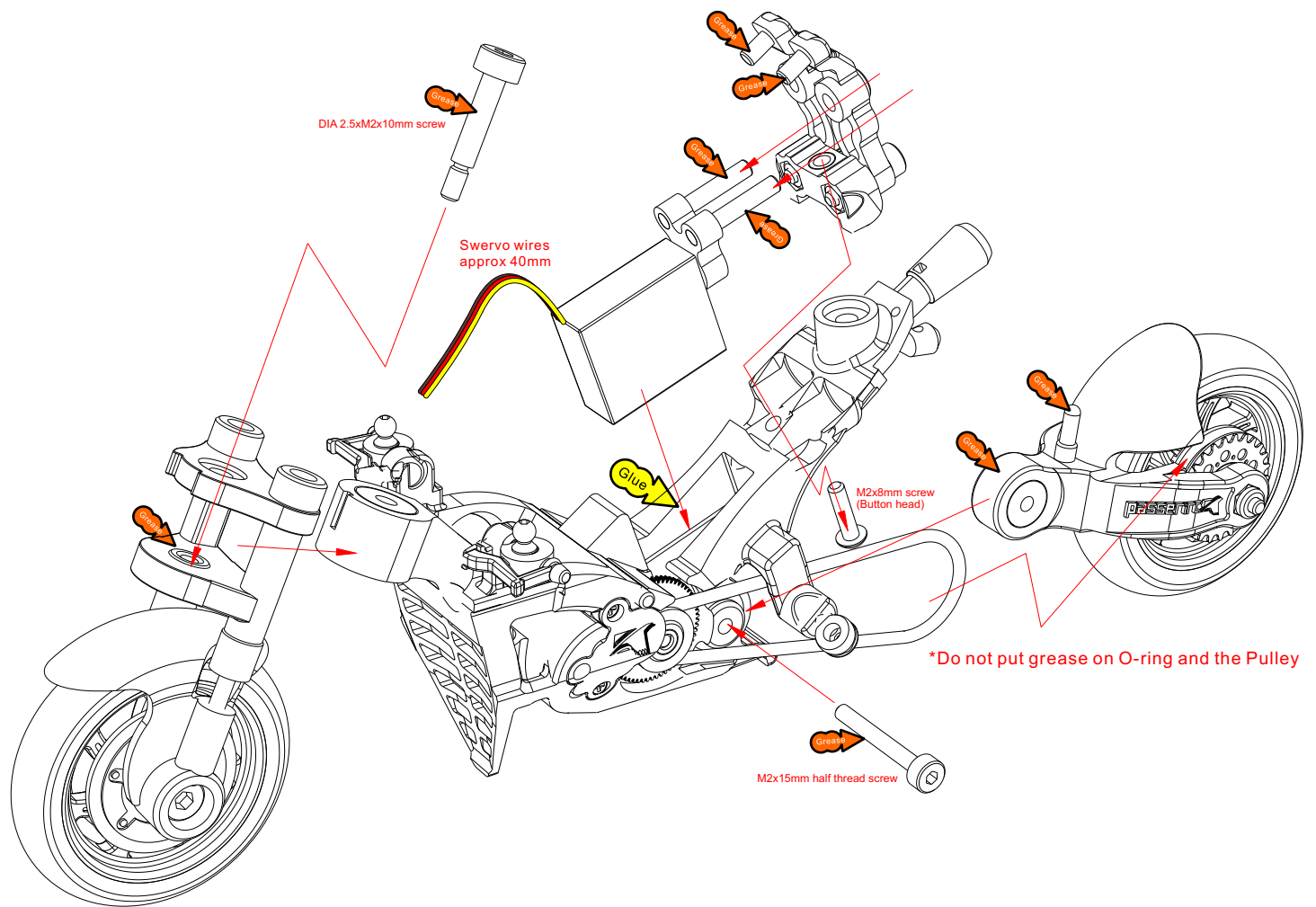

B - CHASSIS ASSEMBLE

CHASSIS

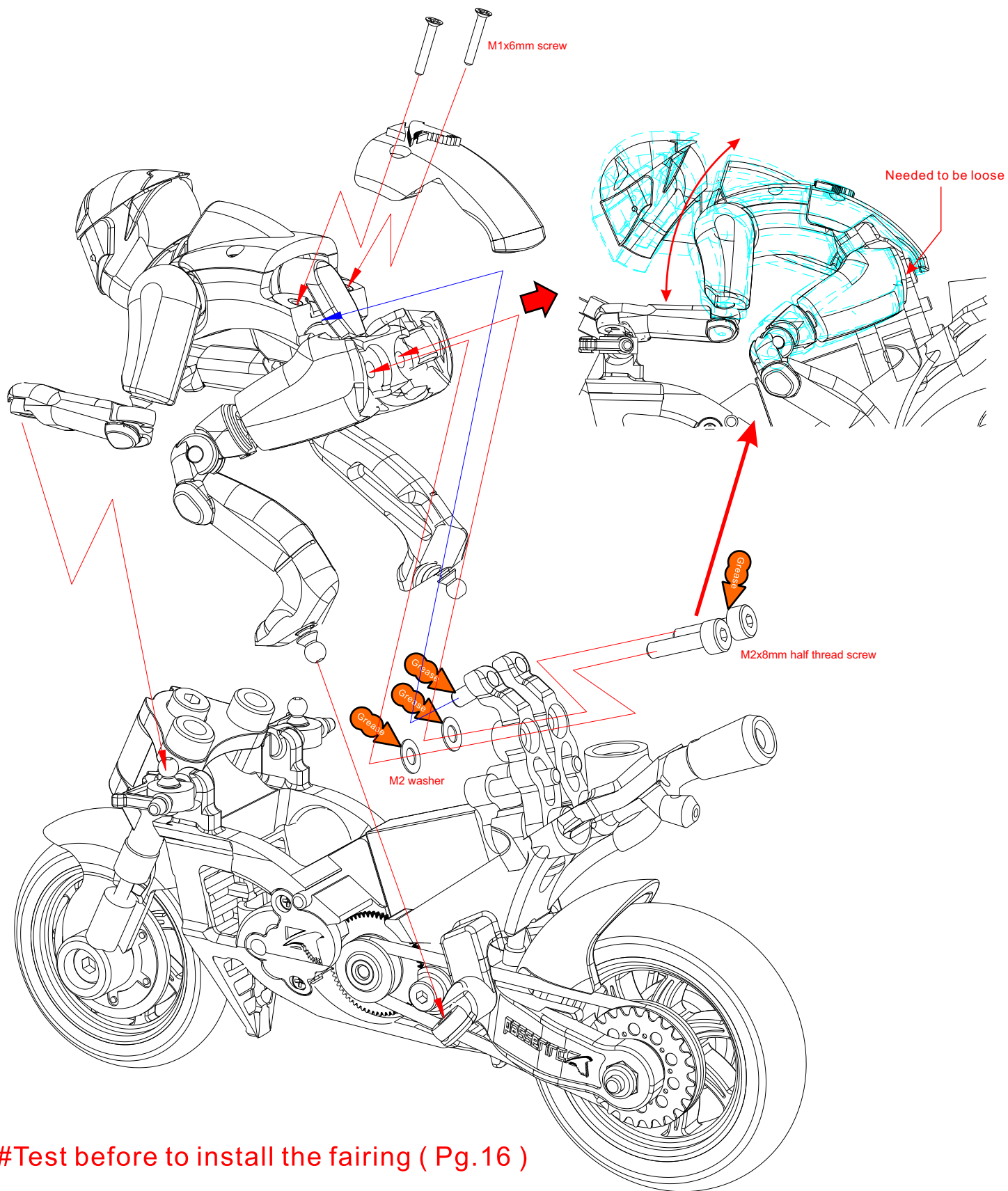

C - BATTERY

SOLDERING WITH THE BT 2.0 PLUG

Link for BT2.0 Plug

<https://flysmart.boutir.com/i/UQicQXAAA>

**Solder cables to
BT 2.0 male plug first**

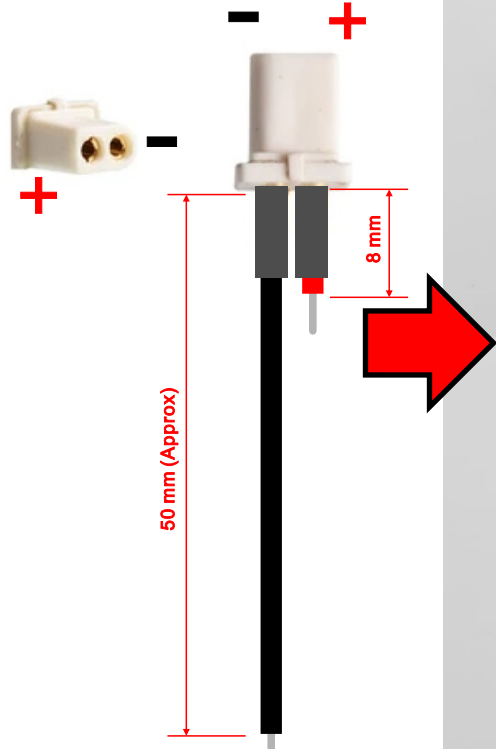

Suggested 24AWG

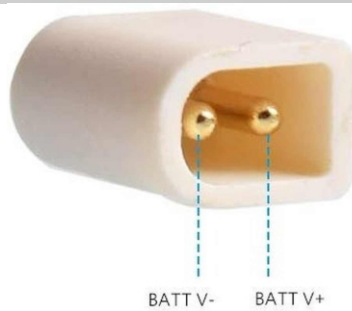
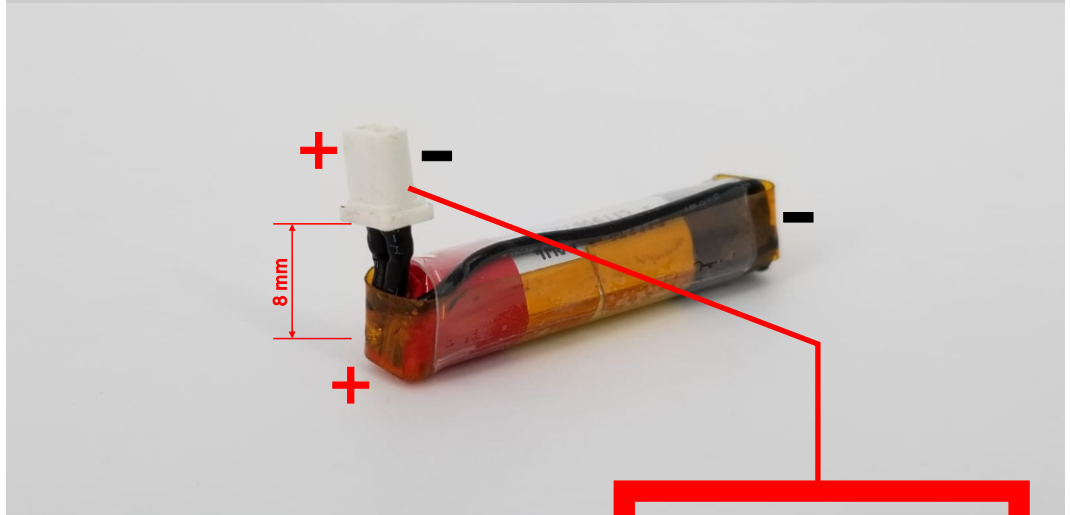
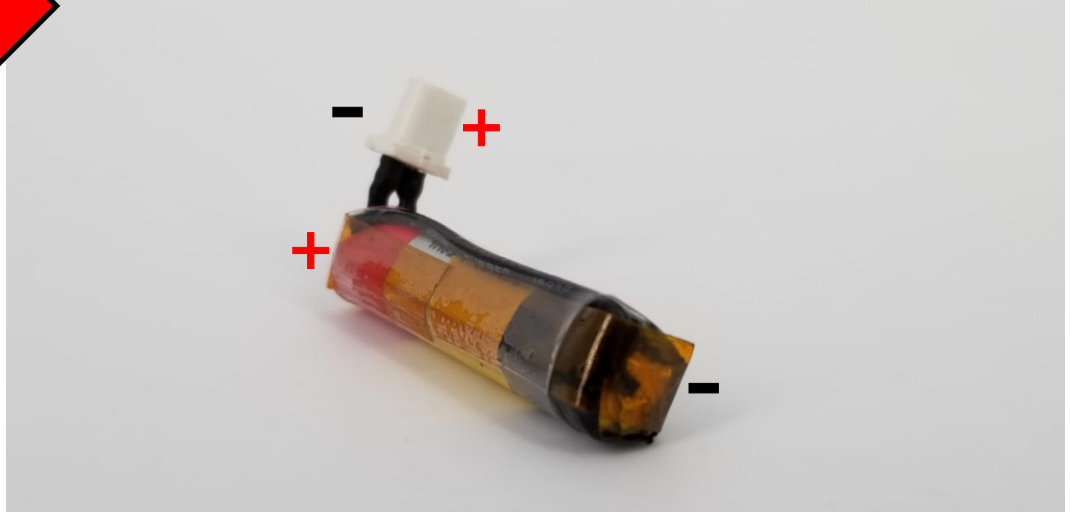

D - RX TO ESC AND SERVO CONNECTION

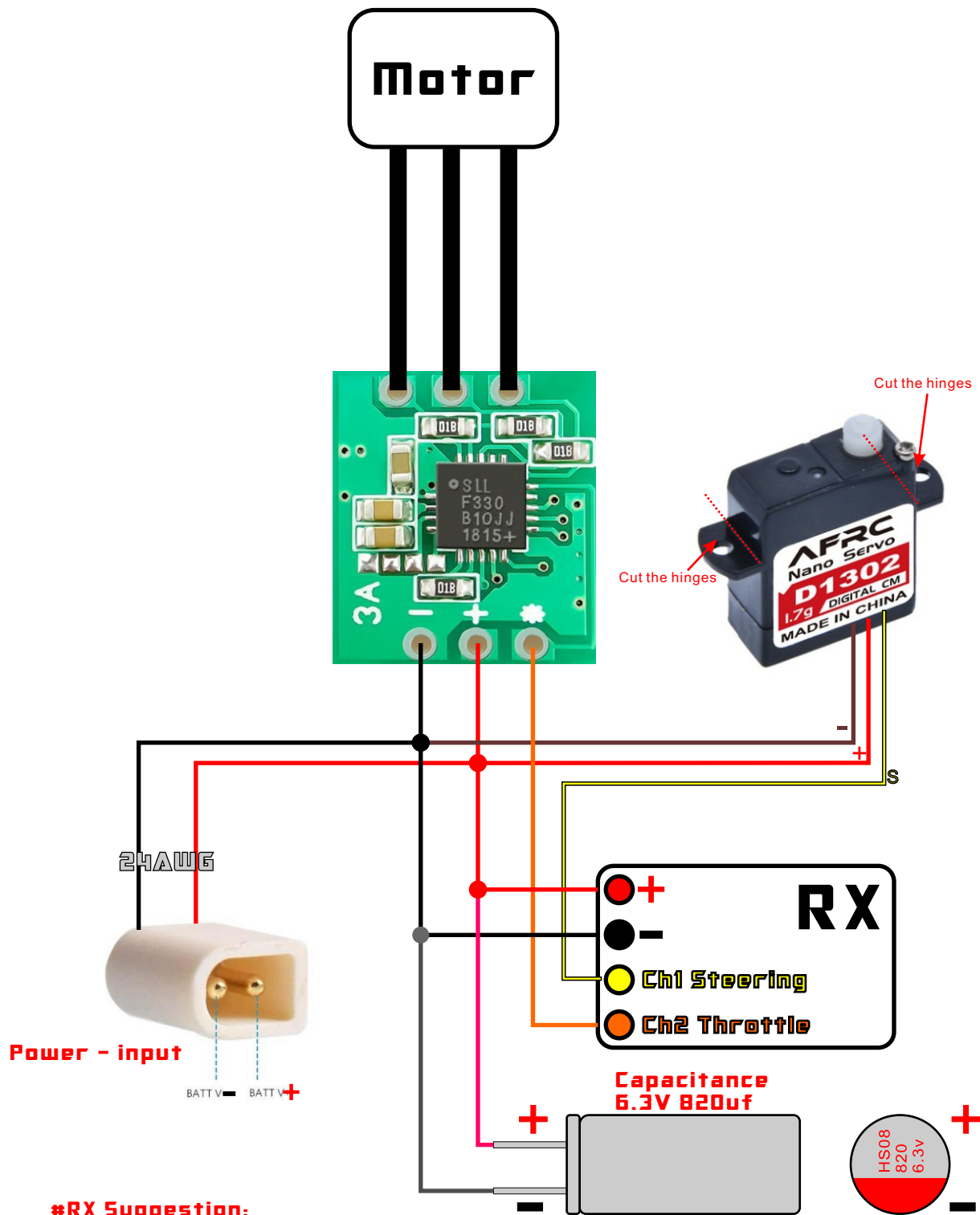

#RX Suggestion:

Futaba - 5-FH55, 7PX, 4PX, 4PV

-https://item.taobao.com/item.htm?spm=a1z09.2.0.0.15322e8dm462Kn&id=609980231117&_u=fjspm6m5cf7
[7px, 4px, 4pv]

-https://item.taobao.com/item.htm?spm=a1z09.2.0.0.15322e8dm462Kn&id=570701266289&_u=fjspm6md9fb
[7PX only]

-https://item.taobao.com/item.htm?spm=a1z09.2.0.0.418e2e8dK1oNjM&id=557195037681&_u=djspm6m79a2
[7px only, Need factory to flash firmware]

KO - ASF, EX-SUR, Propo EX1, EX6, Esprit 4

https://item.taobao.com/item.htm?spm=a1z09.2.0.0.436e2e8d0mUhKP&id=617152979551&_u=fjspm6mdcb3

5ANWA - All Series

https://item.taobao.com/item.htm?spm=a1z09.2.0.0.67002e8djJVof5&id=619865671325&_u=8jspm6m46a7

Flysky - AFH05 3, NB4 Noble4 8Z, 6LA, 6LR, 0RZ

https://item.taobao.com/item.htm?spm=a1z09.2.0.0.75532e8d0s3FZ&id=619714246526&_u=8jspm6m860f

Flysky - AFH05, GT3C

https://item.taobao.com/item.htm?spm=a1z09.2.0.0.67002e8dLd7MUs&id=593348910819&_u=hjspm6m3e15

E - FAIRING INSTALLATION

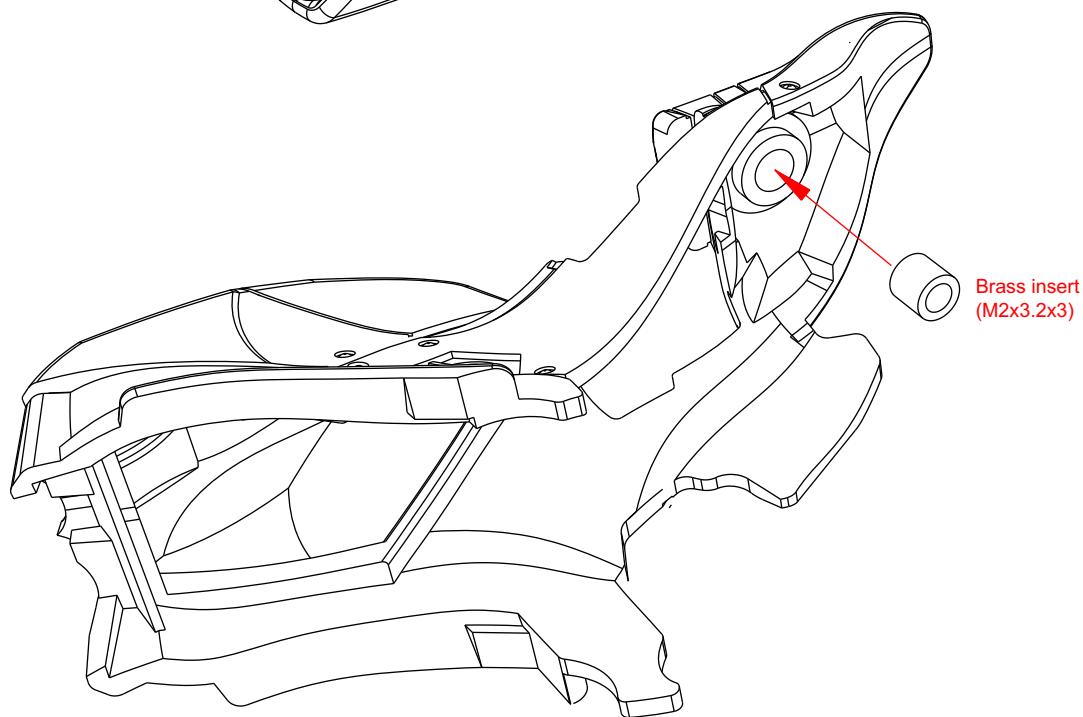
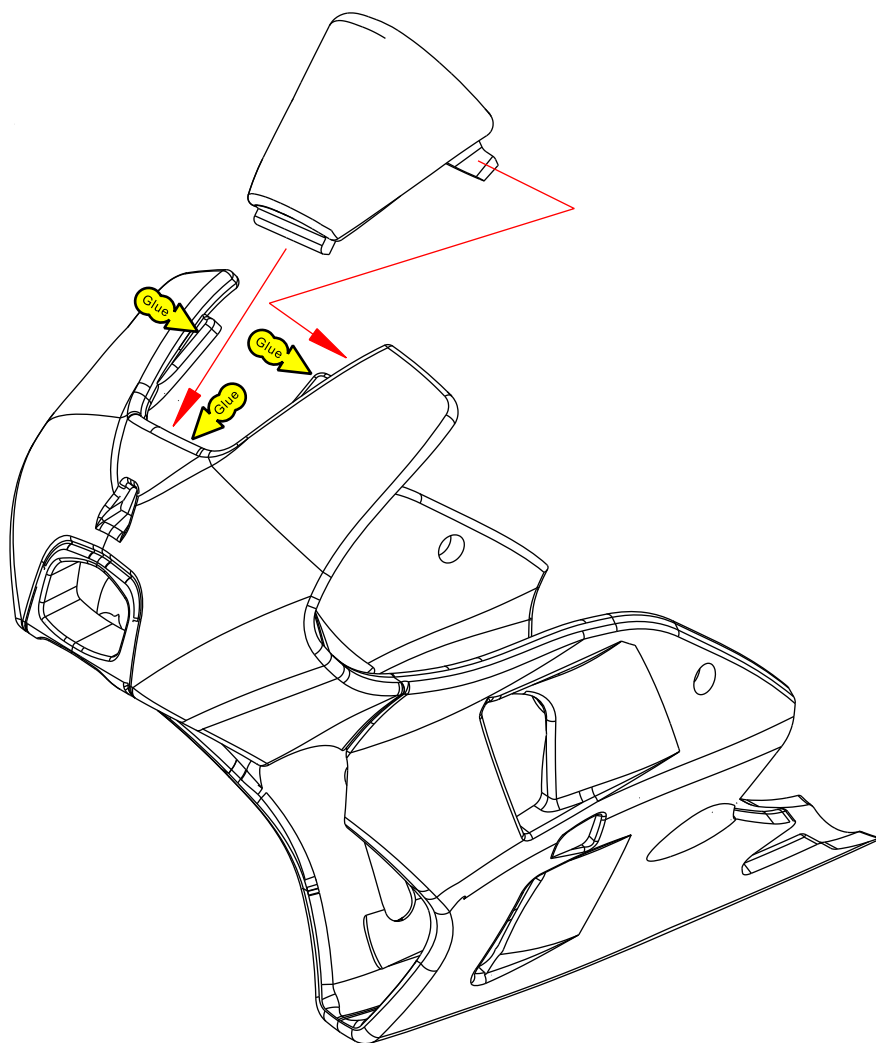

E - FAIRING INSTALLATION

PG. 11

(FOR KEVIN TO THE CHASSIS INSTALLATION)

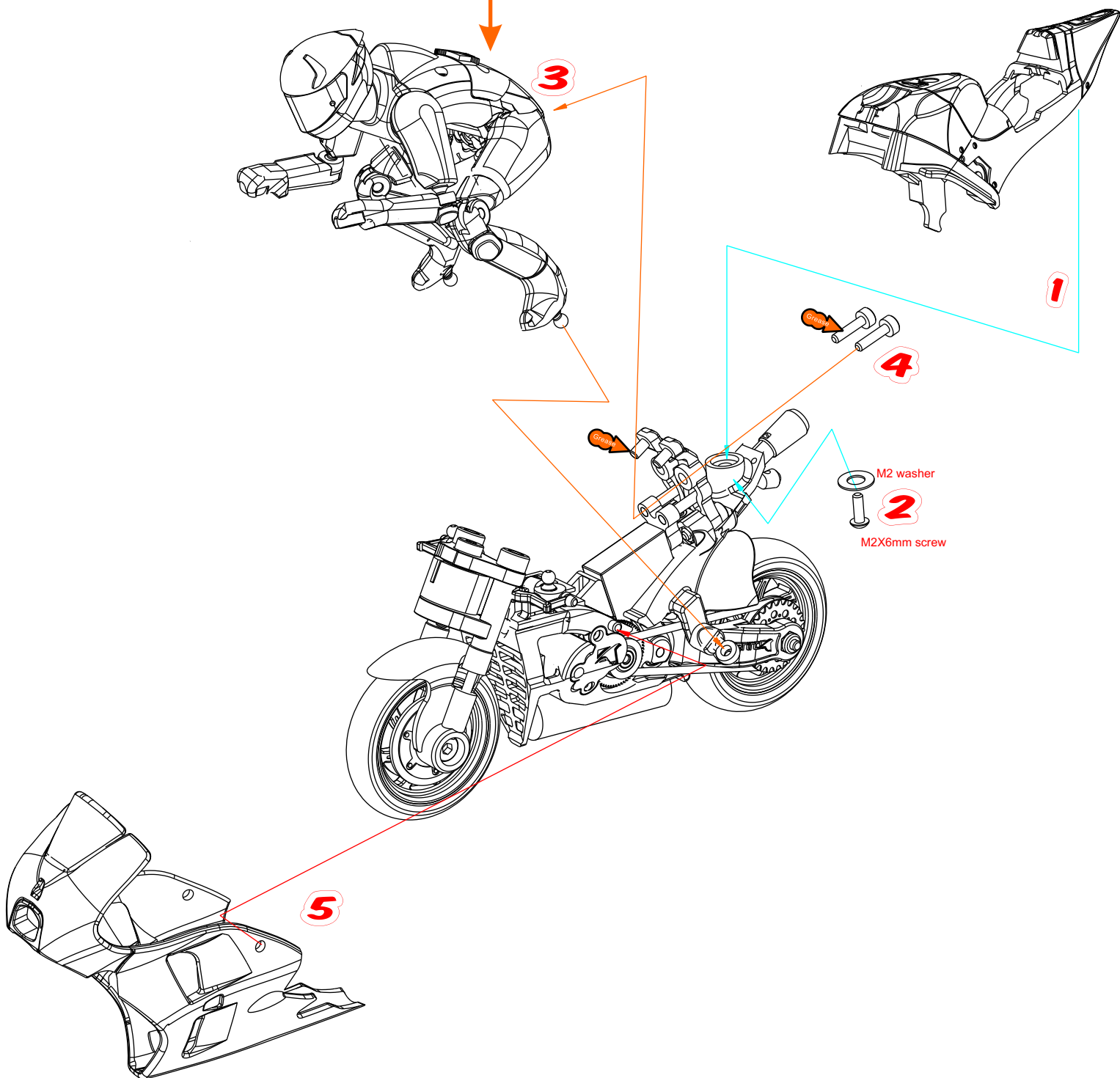

E - FAIRING INSTALLATION

