

感谢您购买 奥兰多汉特 攀爬系列 **ORLANDO HUNTER** 模型。

请您务必仔细阅读说明书，根据说明书的提示来帮助您完成您的模型。本套件为KIT散件版本，需要您动手组装上色及调试。

Thanks for choosing **ORLANDO HUNTER** ROCK CRAWLER Series **ORLANDO HUNTER** model. Please read our instructions carefully, and following our instructions to help you finish assembling the model. The kits are parts, need assembling, painting and debugging by yourself.

本套件不含电子设备，您至少还需购买：

The kits are not including the following parts which you need to buy:



发射机 Transmitter    接收器 Receiver    调速器 Mini ESC    减速电机 Motor    2.2g 舵机 2.2g Servo    锂电池 Li-po    充电器 Charger

您还需要购买涂料、遮盖胶带、流缝胶、美工刀等工具辅料，来协助您完成您的模型。

Besides, in order to finish your model, following Supplementary material you also need to buy: Coating, Masking Tape, Utility Knife.



涂料 Coating    遮盖胶 Masking Tape    美工刀 Utility Knife

您还可以升级灯光设备，选择微型灯光控制器、LED灯珠及贴片，使模型更仿真。还可选择轮毂配重环，降低整车重心，提高姿态仿真。

Besides, in order to upgrade your model, following light material you also need to buy: Mini Lamp control, 4mm LED bulb, smd LED, balance weight.

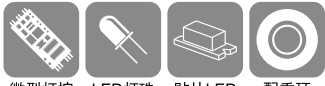

微型灯控 Lamp Control    LED灯珠 4mm LED    贴片LED SMD LED    配重环 Balance Weight

## ⚠ 注意 ATTENTION

组装完成后的模型内含有高减速比齿轮及微型传动系统，请不要尝试使用一切外力强制推动汽车模型。这将可能损坏传动系统及齿轮组件！

模型内含有微型连接件及外观仿真件，请防止高空坠落或挤压模型。这将可能损坏微型部件及外观零件！

请勿将模型长时间放置于阳光下，这将可能加速塑料及橡胶的老化！

After finish assembling the model, please do not use any large strength to push the model, since the inside have high reduction ratio gearwheel and mini transmission system, if do will cause the transmission system be damaged!

Since the model have the mini connection parts and simulation parts inside, please avoid the model be altitude fall or squeezed, otherwise, it will cause the damage of mini connection parts and simulation parts!

Please do not put the model in the sun at long time, otherwise, it will accelerate aging of the plastic and rubber parts!

## ⚠ 警告 WARNING

套件内用于包装的塑料袋使用后请及时收好，或者丢弃在可回收垃圾桶内。请勿让儿童当做玩具，可能会导致窒息危险！

The package bag of kits, after using please promptly put away or throws into the recyclable rubbish bin, if get by child, might have choking hazard!

## ⚠ 警告 WARNING

本套件不适合14岁以下使用！

The kits are not suitable for child under 14 years old!



套件内含大量微小零件，若儿童吸入或误食，可能会导致窒息等危险！请务必放置于儿童不易接触的地方！

The kits including many mini parts, if the child inhalation or mistake eaten, can cause choking or other serious hazard!

Please be sure put the model at the place where child can not touch it!

SIZE 132th

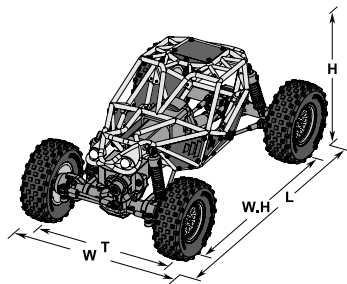

## 尺寸/参数 SIZE / DATA

| 长度 L  | 宽度 W | 高度 H | 轴距 T | 轴距 W.H |
|-------|------|------|------|--------|
| 122mm | 70mm | 55mm | 61mm | 89mm   |

## ⚠ 提示 TIPS

在开始组装前，请准备好所需要用到的工具，按照说明书左侧提示打开相对应的包裹（不要将所有零件包全部打开或全部取出，以免弄混或者丢失），取出相对应的零件（只需要取出左侧标注的零件数量）。因个别零件尺寸比较小，特别是螺丝等小零件，非常容易丢失，使用小盘子、小盒子等来放置待组装的小零件，能有效防止其丢失。

取出零件后如发现毛刺或飞边的，请先用美工刀进行修整，再用砂纸打磨光洁后再进行组装。进行这一步骤后将对组装完成后运行的流畅性和美观性有进一步提升。

组装小零件时注意控制力度，以免损坏零件或使零件掉落而丢失。

Before assembling, please according the instructions tips to open and take out corresponding package, ready for all the tool you need (please not open all the package, it will cause the parts lost or confused). Because some spare parts are really very small, especially the screw etc., which is easily missing, you can put them into a small dish or box first to avoid missing.

Before assembling check the spare parts first, if any burr found, please use utility knife to make it flat, and then use sandpaper to make it smooth. After doing this the fluency and aesthetics of the model will be upgraded.

During assembling the spare parts, please do not use over strength or else will cause the spare parts break or drop.

## 部件/编号对照 PARTS / REFERENCE NUMBER

以下为 奥兰多汉特 攀爬系列 **OH32Xm KT** 所包含的所有零部件编号及数量对照表。  
如组装或者使用过程中损坏或者丢失其中一些部件，可按照零部件编号购买相应的零部件用以替换。  
如需要对模型进行改装及加装，也可按照所需要改装或加装的零部件的编号进行购买。

Following is the comparison table of all spare parts and numbers of the **Orlando - Hunter** ROCK CRAWLER Series **OH32Xm** Model.

During the assembling, if some spare parts break or lost, you can according the number in the chart to buy a new one to replace it. If need remodel or adding, also can according the chart to buy some additional spare parts.

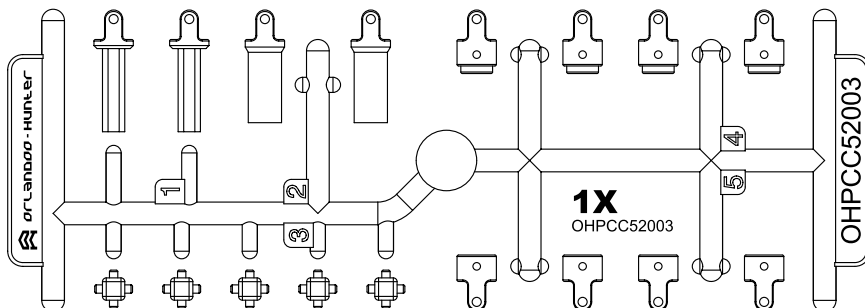
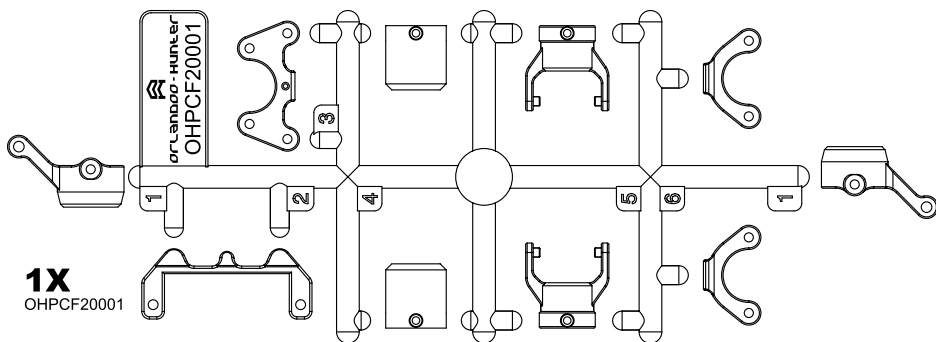
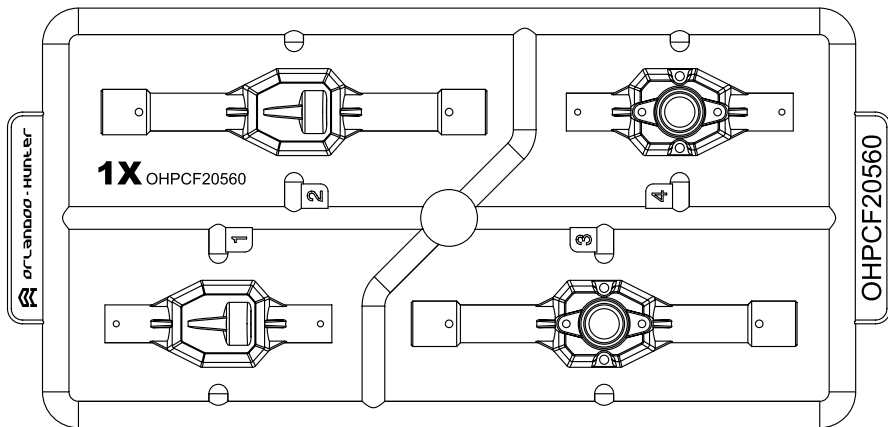

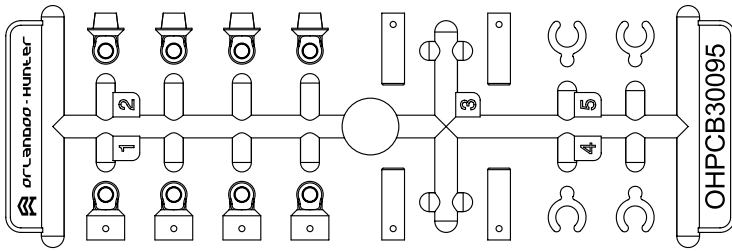

**1X** OHPCH22010

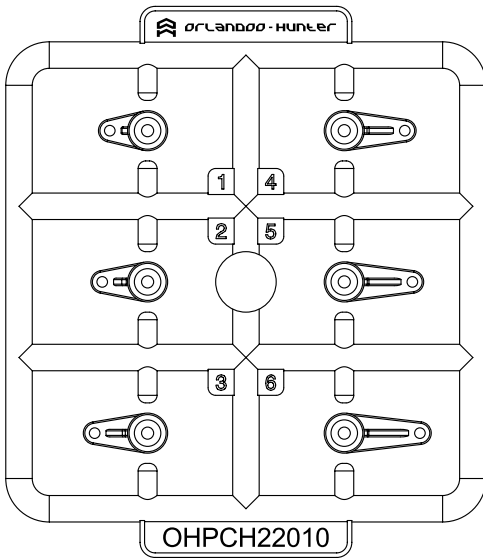

**2X** OHPCA20124

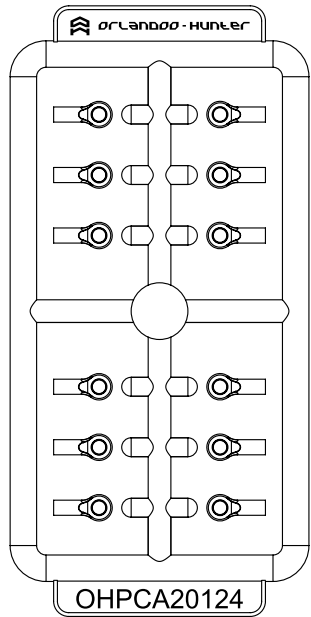

**1X**  
 OHPCH30095

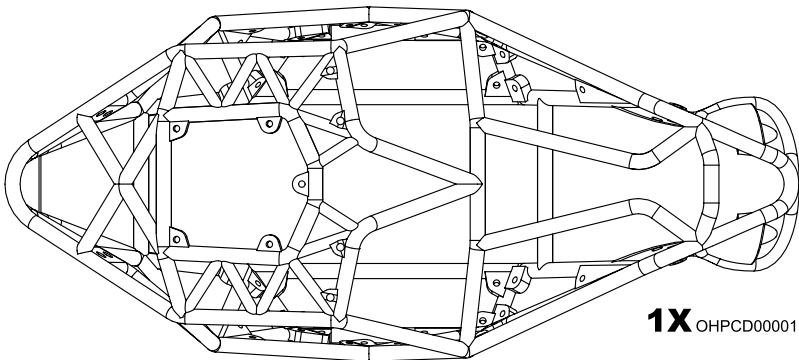

**1X** OHPCD00001

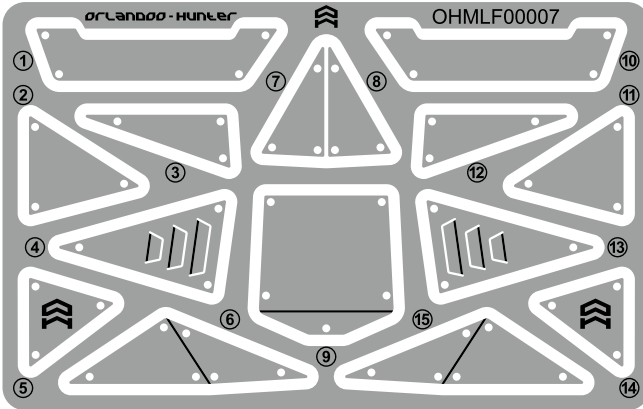

**1X** OHMLF00007

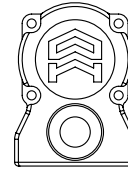

**1X**  
OHPC35202 **1**

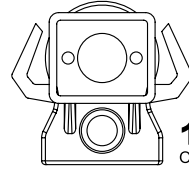

**1X**  
OHPC35202 **2**

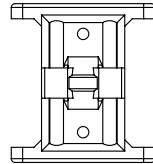

**1X**  
OHPC35202 **3**

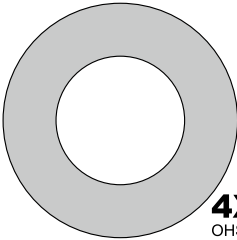

**4X**  
OHSE03117

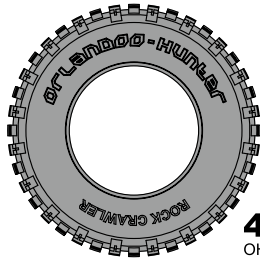

**4X**  
OHTEC18001

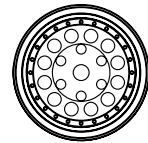

**4X**  
OHPCG34001

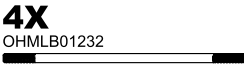

**4X**  
OHMLB01232

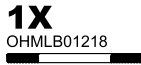

**1X**  
OHMLB01218

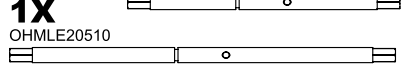

**1X**  
OHMLE20360  
**1X**  
OHMLE20510

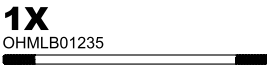

**1X**  
OHMLB01235



**4X**  
OHMLB01220

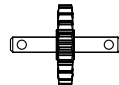

**1X**  
OHMCA05194



**1X**  
OHMCA05191



**2X**  
OHMLC20003



**2X**  
OHMLC20001

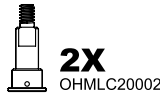

**2X**  
OHMLC20002

**2X**  
OHMLM21625

**2X**  
OHMLM00640



**2X**  
OHMCB05160



**2X**  
OHMCB05080

**2X**  
OHMLM00835

**2X**  
OHPJE00016

**2X**  
OHPJQ10050



**4X**  
OHMLD01010

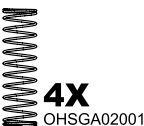

**4X**  
OHSGA02001

**2X**  
OHBG40725

**4X**  
OHBG30620

**10X**  
OHBG20520

**OH32Xm KT**



**26X**  
 OHMLA20162

**1X**  
 OHMLA2016B

**4X**  
 OHSW90102

**1X**  
 OHSW82002

**55X**  
 OHSW01002

**8X**  
 OHSW01003

**4X**  
 OHSW01005

**8X**  
 OHSW01204

**10X**  
 OHSW01205

**3X**  
 OHSW01503

**6X**  
 OHSW01505

**2X**  
 OHSW11603



**1X**  
 OHTLB32001

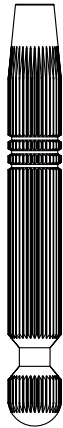

**1X**  
 OHTLB10020



**1X**  
 OHTLB40009



**工具包内包含 TOOL CONTENTS**

十字螺丝刀  
 六角锁胎器  
 内六角扳手  
 双面减震垫

Phillips Screwdriver  
 Nut Driver  
 "L" Type Hexagon Screwdriver  
 Double Side Tape

以下图标将会出现在接下来的装配图中，请先了解图标的含义！  
 Following Icon will appear on the assembling chart, please understanding its meaning first !



制作两份  
 Make  
 Two Copies



制作四份  
 Make  
 Four Copies



需上色  
 Requiring Color



选择  
 Requiring  
 Select



注意  
 Attention

**A**  
打开包裹“A”

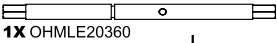

1X OHMLE20360



1X OHMCB05160



1X OHMCB05080

1X OHMLM00835



1X OHPJE00016



1X OHPJQ10050



4X OHBG20520

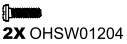

2X OHSW01204

**1**

OHMLE20360  
OHMLM00835  
OHPJE00016  
OHMCB05160  
OHPJQ10050  
OHPCF20560 1  
OHBG20520  
OHMCB05080  
OHBG20520  
OHPCF20560 4  
OHMCB05080  
OHBG20520  
OHBG20520  
OHSW01204  
OHSW01204

! 螺丝不要拧的太紧!  
Do not twist the screw too tight!

! 轴承嵌入后保持平整及到位!  
After bearing embedded remain flat and in place!



1X OHMLA20162



3X OHSW01503

**2**

OHSW01503  
OHSW01503  
OHSW01503  
OHMLA20162  
OHPCH22010 3  
OHPCF20001 2

! 本套件内不包含舵机!  
The kits are not including the servo.

请在安装舵机前调整好舵机中立点，  
按上图安装舵机摇臂，舵机摇臂和舵  
机底面呈90度角。  
Before fixed the servo, please set the  
intermediate point, according the above  
chart to fix the arm of motor, the arm should  
vertical to the bottom surface.

90°



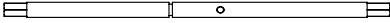

1X OHMLE20510



1X OHMCB05160



1X OHMCB05080



1X OHMLM00835



1X OHPJE00016



1X OHPJQ10050



4X OHBG20520



2X OHSW01204

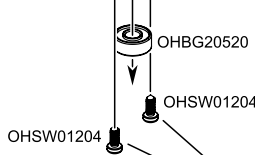
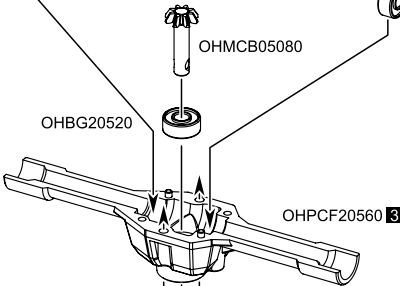
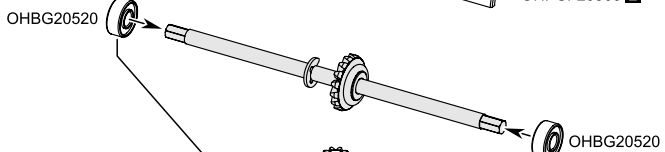
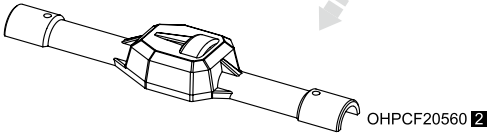
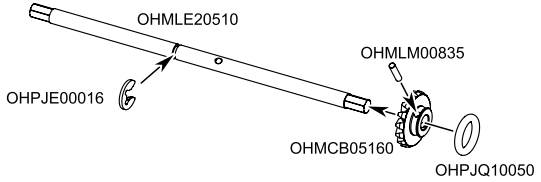

螺丝不要拧的太紧！  
Do not twist the screw too tight !



轴承嵌入后保持平整及到位！  
After bearing embedded remain flat and in place!

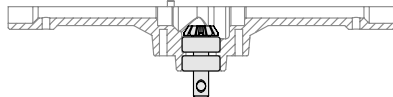



**2X** OHMLC20003



**2X** OHBG30620



**6X** OHMLA20162



**4X** OHSW01003



**2X** OHSW01205

**6**

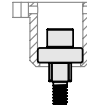

轴承嵌入后保持平整及到位！  
 After bearing embedded remain flat and in place!

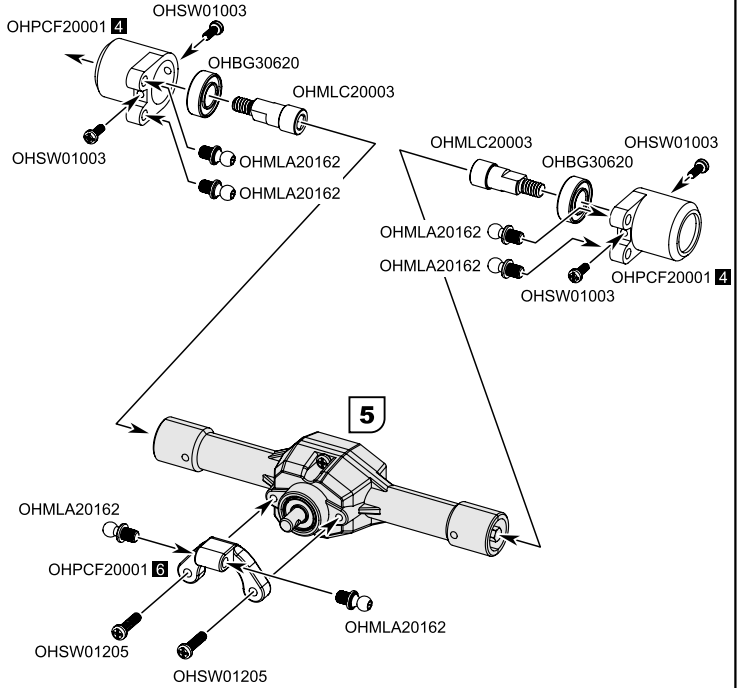

注意零件方向！  
 Pay attention the direction  
 of the spare parts!

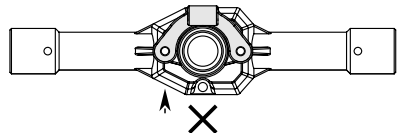
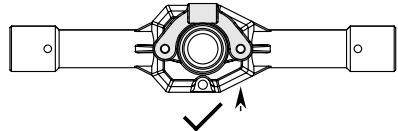

**B**

打开包裹“B”

1X OHMLB01218

**7**

OHPCA20124

OHMLB01218

OHPCA20124

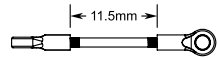

装配后请测量平面至平面距离约为11.5mm，两端拉杆头成90度角。

After assembling, please measure the distance between planes should be about 11.5mm, both two rod ends should be 90 degree.

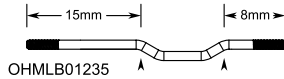
**8**

OHMLB01235



请按照图示折弯。

Please bend the rod as shown.

OHPCA20124

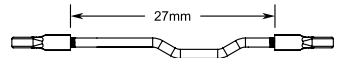

装配后请测量平面至平面距离约为27mm，两端拉杆头保持平行。

After assembling, please measure the distance between planes should be about 27mm. Both two rod ends should keep parallel.

1X OHMLB01235

**9**

OHPCA20124

**4X**

OHMLB01220

OHPCA20124

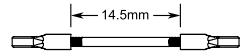

装配后请测量平面至平面距离约为14.5mm，两端拉杆头保持平行。

After assembling, please measure the distance between planes should be about 14.5mm. Both two rod ends should keep parallel.

4X OHMLB01220

**10**

OHPCA20124

**2X**

OHMLB01232

OHPCA20124

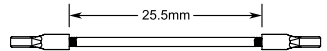

装配后请测量平面至平面距离约为25.5mm，两端拉杆头保持平行。

After assembling, please measure the distance between planes should be about 25.5mm. Both two rod ends should keep parallel.

2X OHMLB01232

**11**

OHPCA20124

**2X**

OHMLB01232

OHPCA20124

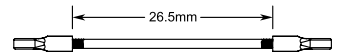

装配后请测量平面至平面距离约为26.5mm，两端拉杆头保持平行。

After assembling, please measure the distance between planes should be about 26.5mm. Both two rod ends should keep parallel.

2X OHMLB01232

**81416**  
**OH32Xm KIT**

12

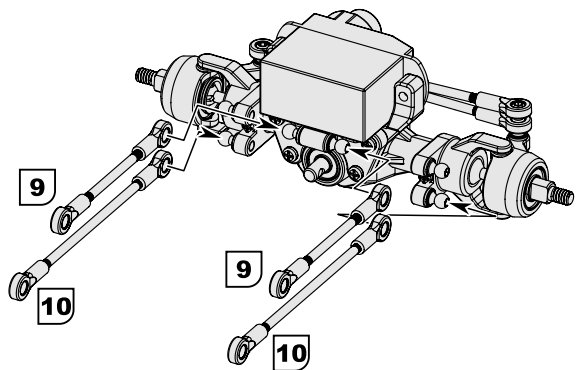
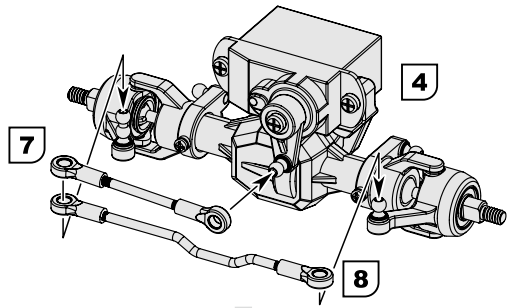

13

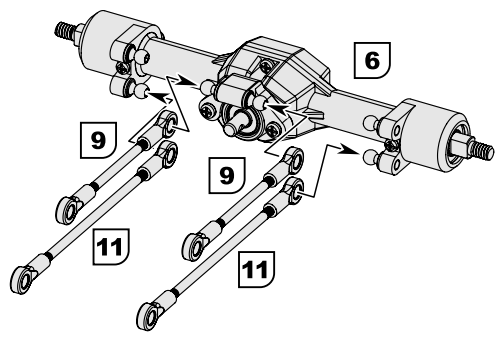

**C**  
打开包裹“C”

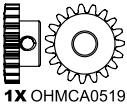

1X OHMCA05191

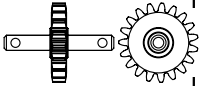

1X OHMCA05194



2X OHBG20520



8X OHMLA20162



4X OHSW01205



2X OHSW01505

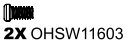

2X OHSW11603

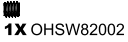

1X OHSW82002



OHSW01205



OHSW01205

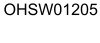

OHSW01205

14



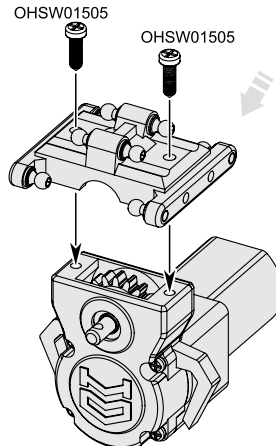
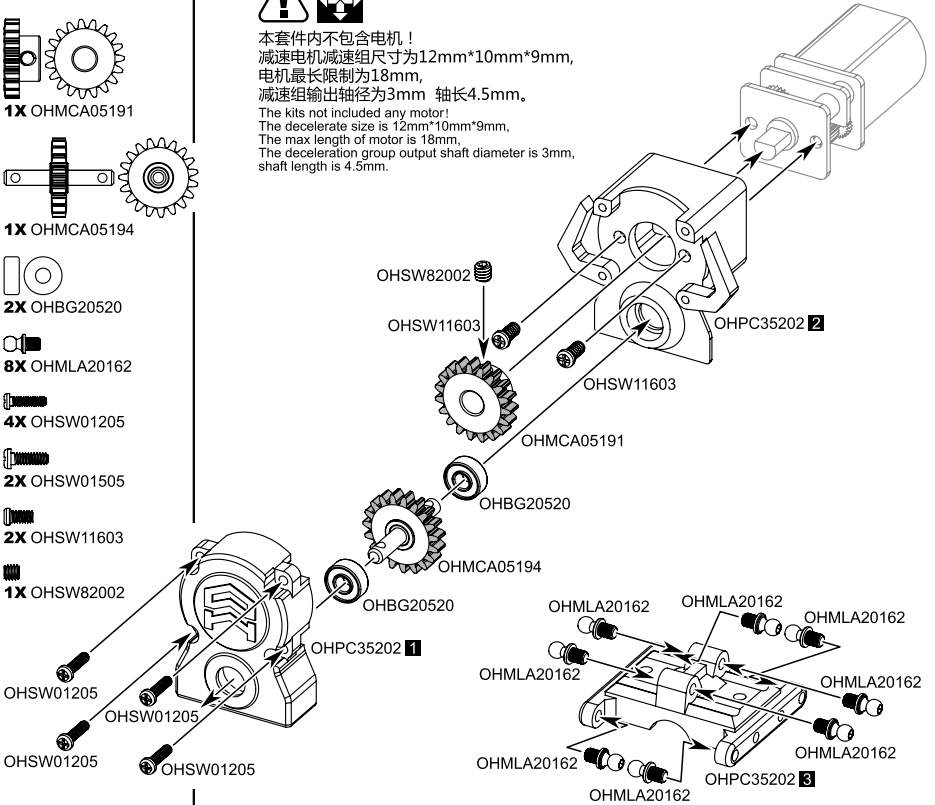

本套件内不包含电机！  
减速电机减速组尺寸为12mm\*10mm\*9mm，  
电机最长限制为18mm，  
减速组输出轴径为3mm 轴长4.5mm。

The kits not included any motor!  
The decelerate size is 12mm\*10mm\*9mm,  
The max length of motor is 18mm,  
The deceleration group output shaft diameter is 3mm,  
shaft length is 4.5mm.





 **4X** OHMLD01010

 **4X** OHSGA02001

 **4X** OHSW01005

**15**

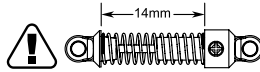

请调整减震距离约为14mm。  
 Please adjust the distance between shock absorber.  
 请使用尖嘴钳夹住丝杆再拧入减震座。  
 Please use Needle-nose pliers clamp to rod then  
 twist into the shock absorber seat.



螺丝请勿拧入过紧，过紧可能导致  
 减震筒身变形，导致顺滑度降低！  
 Do not twist the screw too tight, if too  
 tight will cause the deformation of the  
 shock absorber tube!

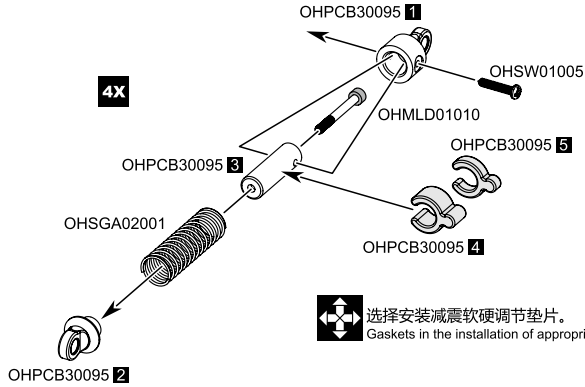

选择安装减震软硬调节垫片。  
 Gaskets in the installation of appropriate selective.

**16**

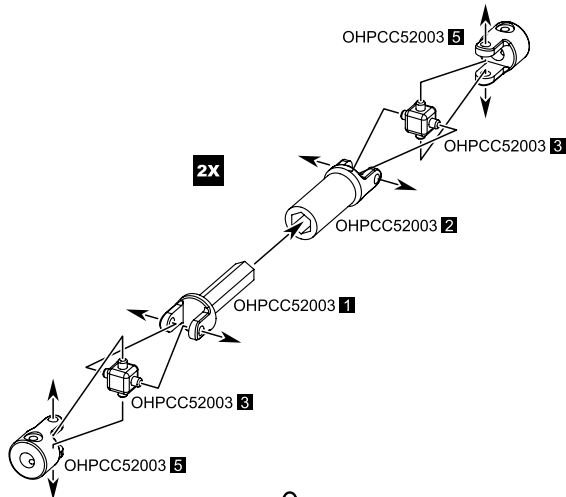

套入万向节时请控制力度，零件较小，请耐心组装。  
 Do not use over strength to set the universal ball, due to the  
 small spare parts, please be patient when assembling.

**D**

打开包裹'D'

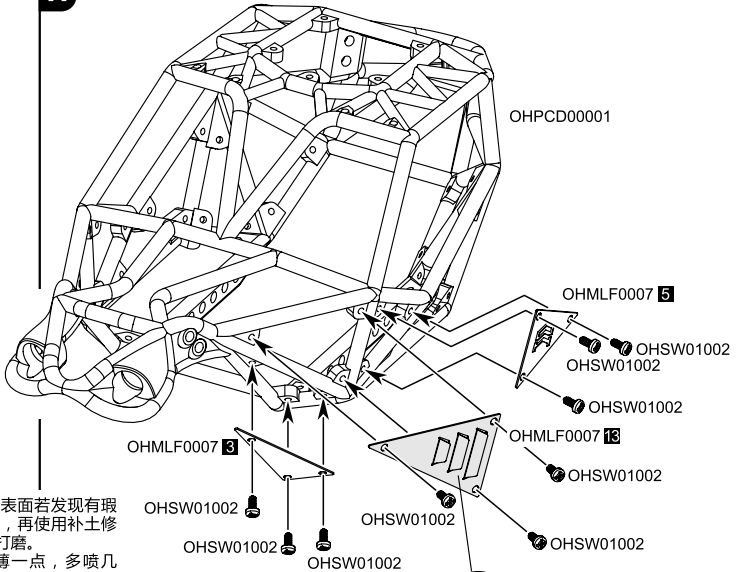
**21X** OHSW01002**17**

在车壳喷漆前，检查表面若发现有瑕疵，请用砂纸打磨后，再使用补土修补凹痕，然后进行细打磨。

喷漆时注意每次喷薄一点，多喷几次，质感更好。

喷保护层后表面再用研磨膏打磨，效果更佳。

喷漆时请戴好口罩、护目镜在室外通风处进行！



自定义颜色  
Custom Colors



请按照图示折弯。  
Please bend the photo-etching parts as shown.



Before painting the car shell, check whether the shell surface have any defect, once found defect, please use the sandpaper make the surface smooth, then use fill soil to cover the dent.

When spray the shell please each time spray little, try to spray more times, it will show better Textured.

After spray the shell, then use the polishing paste to polishing, will get better effective.

When spray the shell, please wear masks and goggle first and work at the outdoor ventilation place!

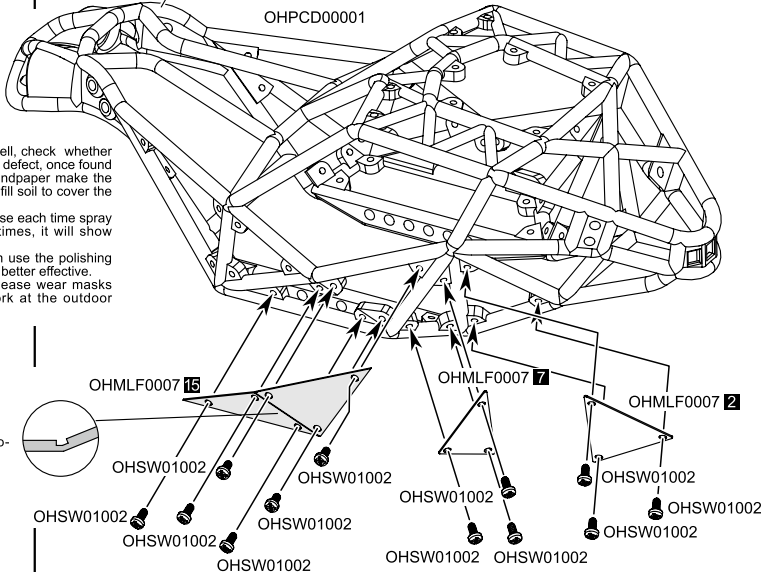

请按照图示折弯。  
Please bend the photo-etching parts as shown.

**81416**  
**OH32Xm KIT**

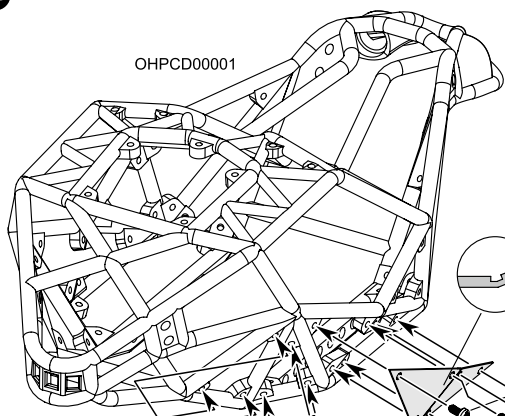

请按照图示折弯。  
 Please bend the photo-etching parts as shown.

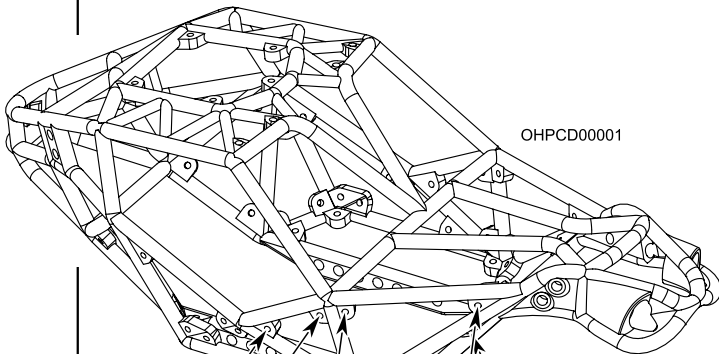
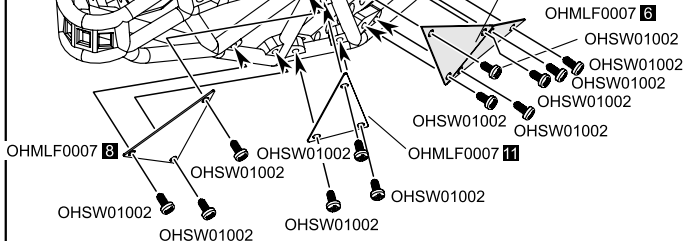

请按照图示折弯。  
 Please bend the photo-etching parts as shown.

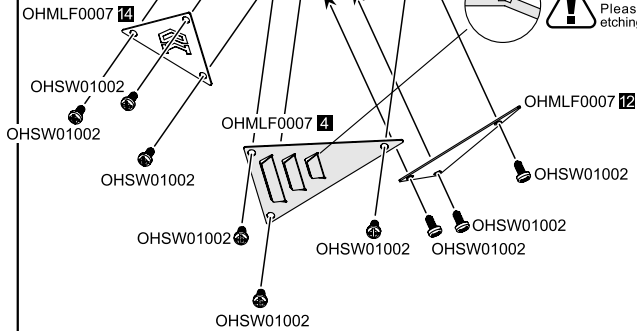

4X OHMLA20162

5X OHSW01002

19



请按照图示折弯。  
Please bend the photo-etching parts as shown.

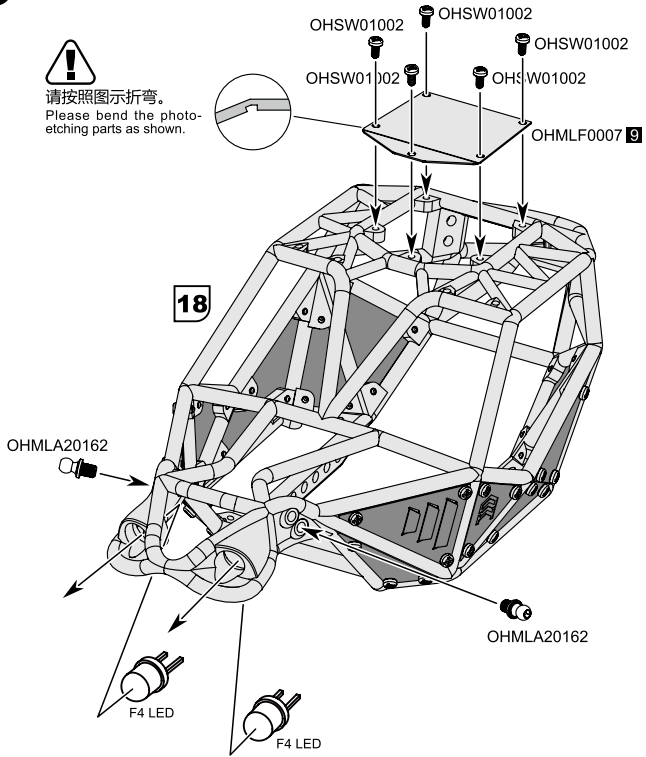

本套件内不包含LED灯组！  
The kits do not included any LED lamp.

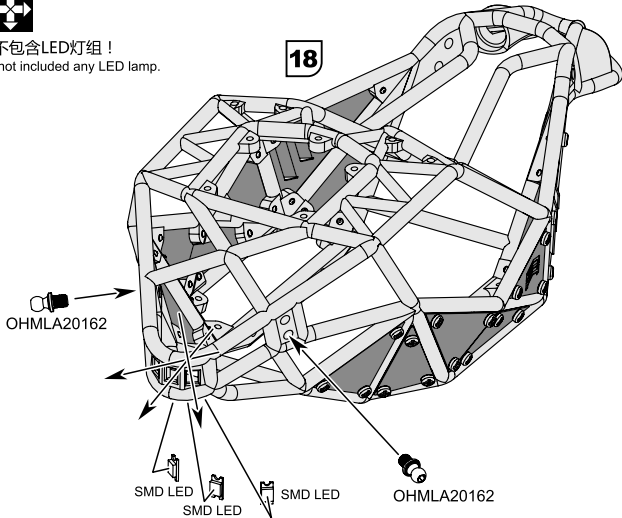



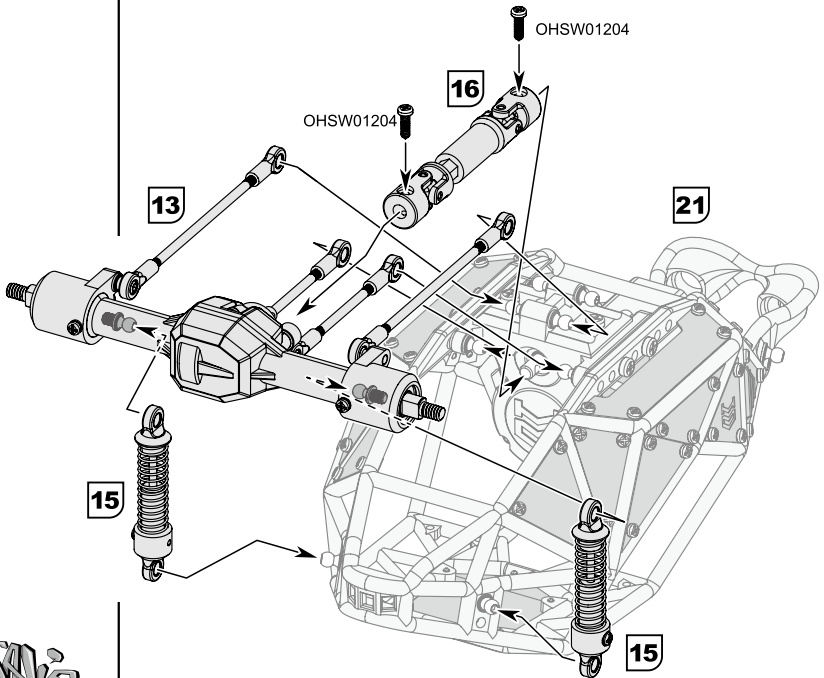
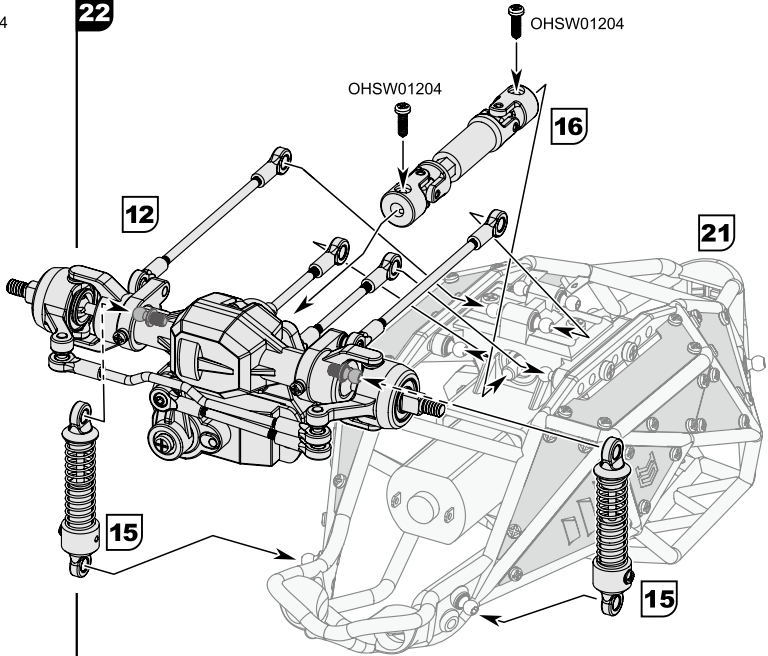

**E**  
打开包裹'E'

  
4X OHSW90102

23

OHPCG34001

OHSE03117

OHTEC18001

4X

OHSW90102

OHSW90102

OHSW90102

OHSW90102

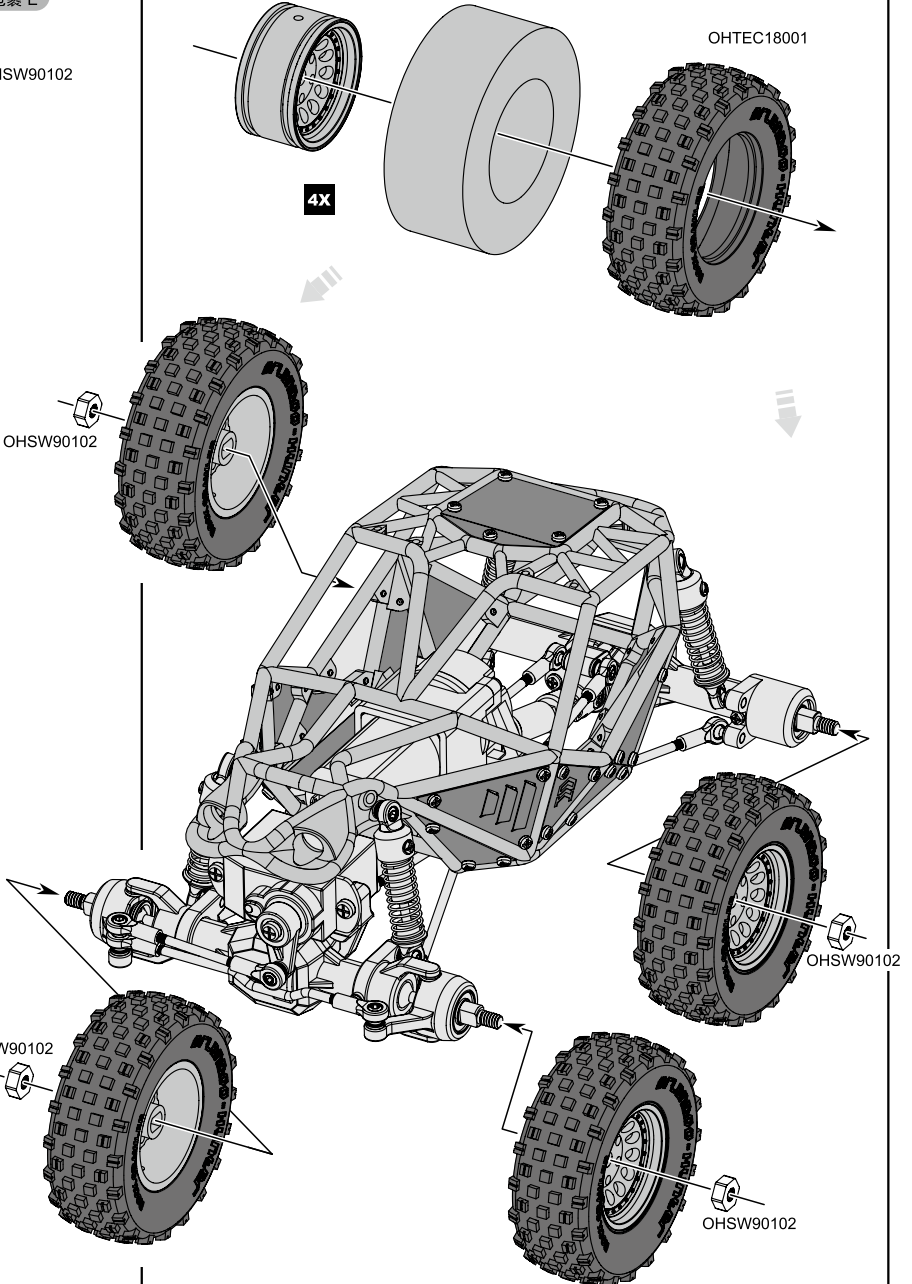

## 车桥/轴距调整 AXLE / WHEELBASE ADJUSTMENT

组装完毕后，如未发现车桥有明显扭曲或偏向一侧，请跳过这一步骤！

如发现车桥有严重扭曲或偏向一侧，请先拆除下拉杆，按照以下图示进行调整！

调整方法：取下拉杆，顺时针拧动拉杆头为缩短拉杆长度，反之增加拉杆长度！

After assembling, if you not found any deformation or offset to one side of axle, please skip this step! If you found any deformation or offset to one side of axle, please dismantle the rod first, then according the chart to adjust it!

Adjustment method: take out the rod, and twist the head of rod in clockwise direction to make the rod shorter, on the contrary will make the rod longer!

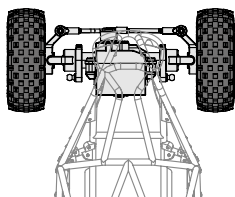

首先拆除下拉杆后将车桥摆正（车桥轴线和车身纵线垂直），检查车桥是否向一侧偏移。

如向左侧偏移，请缩短右侧上拉杆或增加左侧上拉杆的长度！反之逆向调整！

调平后将下拉杆装回。

Dismantle the rod, then straightened the axle (axis of Axle should be perpendicular to the body longitudinal line) Check whether axle is offset to one side, if offset to the left, please shorten the rod on the right or increase the length of the lever on the left side!

Or adjustment on the contrary! After it on the level! Then fix back the under rod.



拉杆调整较繁琐，请耐心调整！  
Rod adjustment is complicated, please be more patient!

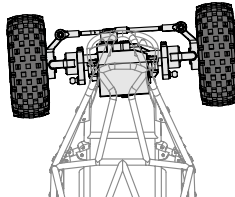

将下拉杆装回后请检查车桥有无向一侧扭曲！

如向左侧扭曲，请缩短右侧下拉杆或增加左侧下拉杆的长度！反之逆向调整！

调平后进入下一步骤！

After assembling the lower rod, check whether the axle offset to one side or not!

As offset to the left, please shorten the length of lower rod on the right side, or increasing the length of the rod!

Or adjustment on the contrary! Then complete above to next step.

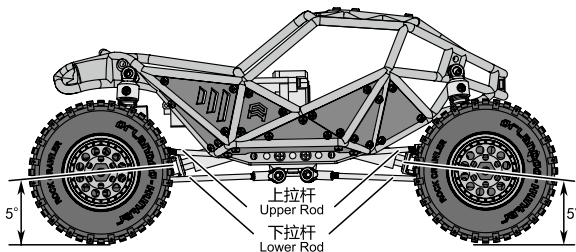

车桥扭曲偏移调平后将模型放置于平面，检查车轮是否有前后位置及车桥角度偏差。如有偏差请按以下说明调整。

前后桥输出轴和平面的倾斜角度约为5度，角度过大或过小可能会增加轴效应，导致模型运行不流畅。

如角度过大，请缩短上拉杆的长度或增加下拉杆的长度；如角度过小，请增加上拉杆的长度或缩短下拉杆的长度。

如前桥太靠前，请同时缩短上下拉杆的长度；太靠后，请同时增加上下拉杆的长度。

后桥调整方式同前桥。

The inclination angle of the front and rear axle between the output shaft and the plane was about 5 degrees, angle is too large or too small may increase shaft effect, and will also cause the model to run not smooth.

If the angle is too large, shorten the length of the upper rod or increase the length of the lower rod; if the angle is too small, increase the length of the upper rod or shorten the length of lower rod.

If the front axle is too close front, please also shorten the length of the upper and lower rod at the same time; if too close the rear side, please also increase the length of the upper and lower rod at the same time. Please note that rear axle adjustment method as same as the front axle adjustment method.

## 配重/重心调整 COUNTERWEIGHT / WEIGHT ADJUSTMENT

模型加入设备后重心位置会发生改变，可在底盘上增加配重来达到前后左右的平衡，底盘以上配重不宜过重，配重物放置位置越低，则车辆稳定性越好。

您还可购买轮毂配重环增加4个轮胎的重量，或使用软铅丝或焊锡丝在轮毂和胎皮之间均匀缠绕达到配重效果，注意左右两侧轮胎配重要一致，前轮可适当增加配重。轮毂配重后，整车重心进一步降低，行进起伏路面时车辆扭曲更加仿真，爬陡坡时更能增加抓地力，重心降低后更不易翻车，性能更稳定！

Gravity position will be changed after the model was added equipment, you can add the balance weight the chassis to achieve equilibrium around. The over Chassis weight should not be too heavy, and the lower placement of balance weight, the vehicle stability will be better.

You can also buy the wheel hub balance weight to increase the weight of the four tires, or use a soft lead wire or solder between the hub and the tire cover wound achieve uniform weight effect.

Please note that the weight between left and right sides of the tire should be same, the front wheel can be appropriate to increase the weight, after the wheel hub the counterweight, the vehicle center of gravity will be lower. When the vehicle travelling the rough road, the twist much more like real vehicle, better grip while climbing a steep hillside, the center of gravity lower, more difficult to overturn and stable performance!